



FOSFA
INTERNATIONAL

CODE OF PRACTICE FOR MEMBER SUPERINTENDENTS

**FOR THE TRADE
BY THE TRADE
WITH THE TRADE**

1 November 2022

GENERAL INFORMATION

Introduction to the Code of Practice for Member Superintendents	i
The Member Superintendents Scheme	ii
Terms and Conditions of Membership - Member Superintendents	iv

PART ONE - OILS AND FATS

Glossary of Terms	1
Functions of Superintendents	3
Operating Practices	4
Shore Practices at Loading and Discharge	4
Ships Practices at Loading and Discharge	6
Mobile Tanks - Road/Rail Vehicles, Portable Tanks	8
Sampling	9
Check List for Operations - Oils and Fats	Annex I
Guidelines for Heating - Oils and Fats	Annex II
Information to be given on Certificates - Oils and Fats	Annex III

PART TWO - OILSEEDS

Glossary of Terms	20
Functions of Superintendents	21
Operating Practices	22
Shore Practices at Loading and Discharge	22
Ships Practices at Loading and Discharge	23
Sampling	24
Check List for Operations - Oilseeds	Annex I
Information to be given on Certificates - Oilseeds	Annex II
Informative Annex - Shipment of Oilseeds - Damage and Contamination	Annex III

PART THREE - GROUNDNUTS

Glossary of Terms	36
Functions of Superintendents	37
Operating Practices	37
Shore Practices at Loading and Discharge	38
Fumigation	41
Sampling	41
Check List for Operations - Groundnuts	Annex I
Information to be given on Certificates - Groundnuts	Annex II
Guidelines on Fumigation	Annex III



FOSFA
INTERNATIONAL

GENERAL INFORMATION



INTRODUCTION TO THE CODE OF PRACTICE FOR MEMBER SUPERINTENDENTS

SEPTEMBER 2002

SCOPE

This Code of Practice sets out the tasks undertaken by superintendents in fulfilling their services to the FOSFA trades in oils and fats and oilseeds, including groundnuts.

OBJECTIVES OF THE CODE OF PRACTICE

The Code's objectives are to -

- a. Provide FOSFA Member Superintendents with detailed functions and operational practices to be performed and reported upon, as appropriate, when superintending FOSFA contracts on behalf of their Principals.
- b. Provide a reference for Principals and others involved in the trades of oils and fats, oilseeds and groundnuts to be aware of the role of the superintendent in fulfilling his duties and responsibilities.

APPLICATION OF THE CODE OF PRACTICE

This Code of Practice applies to all FOSFA Member Superintendents and constitutes part of their terms and conditions of membership.

The extent to which the procedures in the Code are applied, in full or in part, is entirely dependent upon the particular circumstances, trade practices, instructions from Principals, and local legislation and regulations. Where they are not followed or adhered to, the reasons shall be stated in a separate report.

CONTENTS OF THE CODE

The Code contains the functions and operating practices for recognised FOSFA Member Superintendents and has been designed to assist trade Principals to ensure that the handling of commodities traded on FOSFA contracts is being performed in a professional, honest, safe and accountable manner, having regard to the factors that might cause deterioration, damage and downgrading of the commodity within the raw material supply chain.

Any material in direct contact with a FOSFA commodity should be compatible with its intended function. In particular, no copper, brass, gun metal or copper containing alloys must be used. All plastic and rubber materials should be food grade.

Part One - Oils and Fats
Part Two - Oilseeds Part
Three - Groundnuts

The Check Lists, Annexes, and Appendices (Typical Certificates) are considered as being integral parts of the Code.

The Code must be read and interpreted in conjunction with the up-to-date Statutory Health and Safety and Dock Regulations in force in the particular country in which it is intended to apply the Code.

THE MEMBER SUPERINTENDENTS SCHEME

1. FOSFA CONTRACTS - THE SUPERINTENDENTS CLAUSE

The Federation's contracts include a Superintendents Clause which states that "Reference in the contract to superintendents, surveyors or representatives shall mean Member Superintendents of FOSFA International. The use of Member Superintendents shall be mandatory except where (a) the contract or national laws or regulations require the use of governmental or other agencies not recognised by FOSFA International, (b) no member superintendent/s is/are available or proximate to the port/s concerned."

2. TERMS AND CONDITIONS OF MEMBERSHIP

Superintendent members shall be restricted to independent superintendents recognised by the Federation for the purposes of superintending under the terms of FOSFA contracts. Operational superintendents cannot be recognised as such under any other category of membership.

Superintendent members or their representatives shall have the right to attend Section Annual Meetings and General Meetings of the Federation. Each superintendent member has the right to one vote at such meetings. They may be elected to the Technical Committee and any of its sub-committees but not to section or other committees but may be co-opted to them. They shall have the right to nominate as many representatives as they wish but only one shall be included in the basic subscription. They are entitled to such discounts as the Council shall, from time to time, determine on services provided by the Federation.

All reports and contractual documents relating to sampling, weighing, tank cleanliness, previous cargoes, etc, required of a superintendent shall be issued only by a recognised superintendent in the Scheme, exceptions as otherwise stated in Paragraph 1, above.

Detailed Terms and Conditions are attached.

3. APPLICATIONS FOR MEMBERSHIP OF THE SCHEME

Applicants may apply for membership in one or more of the commodity sections, namely, the Oilseeds Section and the Oils and Fats Section. On admission to membership, the section/s in which they are recognised will be published annually in the Federation's Handbook and on the Federation's website.

Applications must be proposed by a trading member and seconded by either a trading member or a full broker member of the Federation. Circumstances may arise, however, when an applicant is seconded by a national trade association, liaison office/officer, government marketing authority or kindred association. As and when this situation arises, the Federation will consider each application on an individual basis.

4. ANNUAL SUBSCRIPTIONS

An annual subscription is payable on admission to membership. All subscription rates are governed by the Council of the Federation and notice is given annually of the rates. Annual subscriptions must reach the Federation's bank account prior to 31 MARCH in each renewal year. If subscriptions are not received by this date, membership will be put under review and may result in suspension, thereby removing the ability to issue FOSFA contractual certificates. As it is the Federation's wish to avoid such circumstances occurring, prompt payment is advised.

5. POWERS OF THE COUNCIL

The Council has the authority to suspend or terminate the membership of any Member Superintendent and has empowered the Technical Committee to monitor the performance of superintendents on their behalf and, from time to time, make recommendations to them.

6. COMPLAINTS AGAINST MEMBER SUPERINTENDENTS

The Council has directed that the Member Superintendents Scheme be administered through the Technical Committee and be subject to a complaints procedure in the event of a complaint arising between principals and scheme members.

Complaints Procedures: A complaint must be made, in the first instance, in writing on official headed company notepaper by an official representative of the company or organisation initiating the complaint. An urgent complaint may be investigated at once by an independent agent approved by the parties concerned and the facts transmitted to FOSFA.

If the Federation requires it, the Member Superintendent shall provide copies of all relevant contractual documents. All complaints will be treated as confidential and the documentation will be kept under conditions of restricted access.

Where a complaint involves supervision or analytical discrepancy, the complainant must immediately instruct the superintendent to send the relevant sample/s to a nominated FOSFA consultant chemist for safekeeping, pending further instructions as to analysis or disposal. In notifying the respondent of the complaint, the Federation will request the respondent to likewise instruct their superintendent to send their relevant sample/s to the nominated consultant chemist.

Establishment of a Complaints Panel: A Complaints Panel will be convened and will present its findings to the Technical Committee, in the first instance, who may then make recommendations to the Council. A complaint may be dismissed by the Complaints Panel if, in the opinion of the Panel, there is no case to answer. The Panel for each case will comprise of the Chairman and/or Vice Chairman of the Technical Committee, a representative from the section concerned, (commercial or technical, who is a member of the Technical Committee) and the Technical Manager.

Time Limits: As a guide, there are time limits for lodging a complaint. Parties making a complaint have 28 days from the arrival of the shipment to make an initial complaint and 40 days to provide the Federation with complete case details. The Federation will inform the respondent member as soon as the initial complaint is received. The respondent member will have 40 days to provide a full written response from the date of receiving the complaint.

Treatment of Complaints - Malaysia: Special arrangements have been developed with the MPOB, whereby they will be invited to assist the Federation's investigation process should a complaint arise against an MPOB licensed superintendent.

TERMS AND CONDITIONS OF MEMBERSHIP MEMBER SUPERINTENDENTS

The following are the terms and conditions of membership of FOSFA Member Superintendents.

- a. To abide by the Rules and Regulations of the Federation, as amended from time to time.
- b. To be totally independent and not associated with any company, firm or organisation engaged directly in the trade in Federation commodities.
- c. To pay an annual subscription on admission to membership and an annual subscription for every year of membership thereafter (such payment to be received by 31 MARCH each year).
- d. To be subject to technical visits and/or inspections at the discretion of the Federation.
- e. To be in possession of up-to-date copies of FOSFA and other international standards that have a direct relevance to the commodities for which the superintendent is recognised, as referred to in the FOSFA Technical Manual.
- f. To be equipped with the correct equipment as laid down in ISO standards and others referred to in the FOSFA Technical Manual.
- g. To be in possession of an up-to-date copy of the FOSFA Code of Practice for Member Superintendents, and to comply with it.
- h. In the case of membership of the Oils and Fats Section, to be in possession of an up-to-date copy of the FOSFA publication 'Carriage of Oils and Fats'.
- i. To conform to national health and safety regulations.
- j. To provide a 24 hour service to the trade.
- k. To agree NOT to sub-contract superintending duties to any other party other than to a FOSFA International recognised Member Superintendent in the relevant Commodity Section, but only then with the agreement of the Principals.

Note: Superintendents are advised to be in possession of the FOSFA Manual (and subscribe to its Amendment Service), as this publication contains the FOSFA contracts.



FOSFA
INTERNATIONAL

OILS AND FATS (PART 1)



1. **GLOSSARY OF TERMS**

This glossary of terms is for use in the Oils and Fats Section/International Trade of Oils and Fats.

Adulteration - Debasement of a named product by the addition of an inferior substance.

Ballast Water - Water carried in special ballast tanks or in cargo tanks in lieu of cargo for stability and to make the ship seaworthy.

Bottom Allowance - Amount to correct tank calibration for bottom irregularities.

Co-mingling - Subsequent loading of another parcel of oil into a ship's tank already loaded with an earlier parcel or simultaneous loading of two parcels.

Contamination - Introduction of another substance, usually by accident, to the named product with resultant damage to that product.

Copper Alloy - Metals such as brass, bronze or gun metal.

Craft - Smaller vessels, river barges, lash barges, coastal ships.

Cargo Record Book (Oils and Fats) - Under MARPOL, oils and fats are classified as noxious liquid substances (Category D). Under Regulation 9 of MARPOL Annex II every ship carrying noxious liquid substances shall be provided with a Cargo Record Book in the form specified by the Convention. The Cargo Record Book shall be completed on a tank-by-tank basis whenever any of the following operations take place -

- loading of cargo
- internal transfer of cargo
- unloading of cargo
- cleaning or ballasting of cargo tanks
- discharge of ballast
- disposal of residues to reception facilities
- discharge into the sea or removal by ventilation

(Under MARPOL, the cleaning and passivation of a ship's stainless steel cargo tank would have to be recorded in the Cargo Record Book).

Dedicated - As applied to carrier, tank, pipeline, pumping systems, is one which is in service with a specific product with which a similar product can be mixed without affecting its quality or is in service with a range of compatible products, all of which can be handled without affecting their quality after routine emptying, draining or clearing of the system but without the necessity to clean. For certain grades of oil, particularly refined oils, contractual parties may impose stringent rules about compatibility.

Deep Tank - Vertical tank built into a cargo vessel for the optional carriage of oil.

Deterioration - Chemically, oils and fats are quite stable, neutral substances. However, during storage and transport two types of deterioration can occur -

- Oxidation.
- Hydrolysis (see below).

Deterioration causes colour and flavour changes (rancidity) which eventually renders an oil or fat unsuitable for food use.

Dip - Depth from liquid surface to calibrated zero at tank bottom.

Flexibles - Hoses of metal (preferably stainless steel) or various plastic or rubber compounds, usually reinforced.

Flash Point - Temperature of oil when vapour ignites under test conditions (ISO 2719).

Flash Point Limit Test - ISO 15267 - Method to determine whether a sample of oil or fat at a given temperature will flash when a test flame is applied to the sample under specified conditions, but the flame is not sustained.

Foots - Comprises two elements -

Visible Foots - The insoluble matter in crude fats and oils, together with occluded oil, which settles at 20 degrees Celsius or at 10 degrees Celsius above the melting point of the fat or oil, whichever is the higher.

Sediment - That part of the insoluble matter in a crude fat or oil which can be centrifugally separated and is the total amount of the unclear layer of components collected at the bottom of the measuring cell after centrifuging. The sediment contains, for example, phospholipids, impurities and dirt, usually dispersed in a water-containing phase.

Gas Free - Condition in a tank where no toxic or explosive gas is present in the enclosed space, and it is fit for human entry without breathing apparatus.

Hydrolysis - Breakdown of fats to fatty acids promoted by the presence of water particularly at higher temperatures. Hydrolysis also promoted by the action of certain micro-organisms. Tanks in which the oil is stored or transported must be clean and dry before use to prevent hydrolysis.

Inert Gas Blanketing - Inert gas, usually nitrogen, put in the ullage space in a pressurised tank to prevent air oxidation of the product.

Insoluble Impurities Content - Dirt and other foreign matter insoluble in n-hexane or light petroleum under conditions specified in ISO 663.

"Litre Weight in Air" - Conventional mass per volume of liquid oil, primarily used to convert volume to mass or mass to volume (ISO 6883).

Manifold - Cross-header with single pipe connection on one side and several connections on the other for collection and distribution of product.

Oxidation - Process in which the fatty acids of oils and fats react with oxygen, resulting in rancidity. Oxygen present in the atmosphere in contact with oils and fats will cause chemical changes in the product which will downgrade the quality. Oxidation proceeds more rapidly as the temperature increases, so advisable to carry out each operation at the lowest practicable temperature. The rate of oxidation is greatly increased by the catalytic action of copper or copper alloys, even when trace amounts are present. Copper and copper alloys must be excluded from the transportation systems. Other metals, such as iron, also have catalytic effects, although less than those of copper. Oxidation is reduced by limiting air contact.

Passivation - A nitric acid wash of high chromium stainless steel ship's tanks to form a very thin oxide film on the metal surface which serves as a protective barrier.

Pigs and Pigging - Spheres, cylinders or articulated cones made of plastic or rubber compounds to be propelled through pipelines to empty contents or separate products.

Pressing-Up - Pumping product into a partly-filled pipeline.

Sea Cocks - Valves below the water line in a ship's hull giving access to the sea.

Stripping - Action of pumping the last residues from a tank.

Total Height - Calibrated height from a tank bottom datum to a reference point at the tank top dip hatch.

Trace Heating - Heating coil or tape running along the length of a pipeline.

Ullage - Space between liquid surface and tank top, more particularly the calibrated measure from liquid surface to fixed datum at tank top.

Weighbridge - Platform capable of weighing vehicles by means of levers or load cells.

Weigh Scales - Usually tanks mounted on weighing machines with similar capacities to weighbridges.

2. FUNCTIONS OF SUPERINTENDENTS

2.1 GENERAL

To act on his Principal's instructions in a professional manner, performing in person those operations required of him, observing conduct of operations by others and protecting the interests of his Principal. The superintendent should report any departures from normal and/or specified practice to his Principal.

2.2 CONTRACT PARTIES

Within FOSFA contracts, a superintendent may be appointed by either Buyer, Seller or both.

2.3 SCOPE OF INTERVENTION

Must be fully acquainted with the relevant FOSFA contract terms, remaining within these, not assuming responsibilities which are not covered by his instructions.

2.4 AUTHORISATION

Following upon 2.2 and 2.3 above, the other contractual party and other interested parties (such as authorities, installations, vessels or Buyers and Sellers in a string) must be advised in detail of the nomination of, and requirements delegated to, the superintendent.

2.5 RESPONSIBILITY

The Principal must accept the immediate and consequential effects and costs to all involved parties of the superintendent's intervention on his behalf.

2.6 MAIN OPERATIONS

2.6.1 The superintendent shall attend operations at loading or discharge to and from conveyances. (Conveyances include containers, road tankers, rail tank cars, river barges and lash barges, coastal ships, ocean ships, land tanks, direct pipelines and any other handling facility that may come into contact with the oil or fat).

He shall report on ships, craft, vehicles, facilities available, tank cleanliness, whether tanks are empty, etc. He shall supervise quantity measurements and participate in preparation of samples for litre weight in air and quality determination and generally perform duties as specified in the relevant contract. He shall further keep a time-log of the activities he participated in or witnessed.

- 2.6.2 Inspect visually tank cleanliness and tank emptiness.
- 2.6.3 Establish weights in accordance with the relevant FOSFA contract, as advised by the Principal.
- 2.6.4 Perform sampling in accordance with ISO 5555 and the relevant FOSFA contract, as advised by the Principal.
- 2.6.5 Issue survey reports and FOSFA Prescribed Report Form (Certificate of Compliance, Cleanliness and Suitability of Ship's Tank), as called for under the contract and/or the local and international legislation. Information to be given on survey reports/certificates, is set out in Annex III. FOSFA's Prescribed Report Forms are contained in the FOSFA publication 'Carriage of Oils and Fats'.

3. OPERATING PRACTICES

3.1 CONDITIONS

As considerable variation of conditions exist under which the superintendent may have to undertake his/her work, the following practices can only be applied where conditions permit.

3.2 GENERAL PRACTICE

The Code effectively constitutes recommendations for the performance of operations, which are basically similar for loading and discharging and may generally be applied to storage, transportation and handling equipment without significant change for the type and size of that equipment.

3.3 PARTICULAR PRACTICE

Included within Part One of this Code is a Check List (Annex I) for typical loading and discharging operations of oils and fats to assist the superintendent in following the sequence of the particular operation.

4. SHORE PRACTICES AT LOADING AND DISCHARGE

4.1 SHORE TANK - FACILITIES RELEVANT TO THE PARTICULAR OPERATION

Information to be obtained from the shore tank facility on capacity, dimensions, construction, materials, internal coating, insulation, heating facilities, suction drains, calibration data, total heights, bottom allowances, safe access.

4.2 SHORE TANK - CLEANLINESS

Information to be obtained from the shore installation on previous contents and method of cleaning. If safely accessible and gas-free, inspect walls and bottom for cleanliness, condition of plates and coatings. Check no internal fittings of copper or copper alloys. Report on loose scale, residues, hardened product on shell, particularly at higher levels. Report on any unusual foreign odour and identify if possible. Where not safely accessible, limited inspection must be made from roof manholes depending upon installation operation for details not visible. If the condition of tank unacceptable, advise Principal and/or reject.

4.3 SHORE TANK - HEATING AND INSULATION

Information to be obtained from the shore tank facility on coil layout, type of coils, heating medium and, if practicable, see live test with design heating medium. Guideline temperatures and rates of heating are included in the 'Carriage of Oils and Fats' publication. Report on shell and roof insulation. If anything found abnormal, advise Principal.

4.4 TANK AND CALIBRATED DEFICIENCIES

Installation operator shall advise any calibration deficiencies such as tank listing, irregular bottom configuration.

4.5 SHORE TANK MEASUREMENT - GROSS DIP

Dipping with steel dip tape with integral stainless steel dipweight is recommended. Dipping to be at dip holes related to calibration data. Tank bottoms to be fully covered for volume calculation. Liquid contents should be stable before dipping. Alternative to dip measurement is ullage measurement from calibrated level, but dip preferred.

4.6 SHORE TANK MEASUREMENT - WATER

Normal means of measuring free water are by water detecting paste, treated paper or electronic means. (Whichever method is used, accurate determination of water content is often difficult because of the nature of the product and the indistinct separation of free water and emulsion layers and moisture in suspension in the lower layer of the oil).

4.7 SHORE TANK MEASUREMENT - TEMPERATURE

Depending on equipment available, temperatures can be measured at various levels by electronic devices fitted with probes or by drawing up sample and measuring temperature in the sampler by hand-held thermometers, digital or liquid in glass. Under no circumstances is glass permitted inside tanks containing oils and fats.

4.8 SHORE PIPELINES - FACILITIES RELEVANT TO THE PARTICULAR OPERATION

Information to be obtained from the shore installation whether pipeline is dedicated to a single product or, if not, information about the previous product for which it was used. Note to be made of pipelines, including construction, materials, capacity, insulation, heat tracing, pigging facilities, line routing, valve separation, line blinds, sampling point and type. Where refined products are to be handled, pipelines should preferably either be dedicated to compatible products or have completely satisfactory means of clearing and cleaning, between grades.

4.9 SHORE PIPELINE - CONDITION

Information to be obtained from the shore installation that pipelines have been fully cleared by effective pigging, which is preferred, or by blowing, (bearing in mind that pipeline layout may prevent complete clearing) or are completely full after full-bore flow against positive head (so either completely empty or completely full). The superintendent must rely upon the installation operator to advise about the line and probable condition based on experience of clearing, pressing-up. He should report condition accordingly.

4.10 SHORE PIPELINE - PIGGING SYSTEMS

Design and operation of pigging system, type of pig and known effectiveness should be reported. Effectiveness of blowing should be reported.

4.11 SHORE PIPELINE - INSULATION AND TRACE HEATING

Report on the type of insulation and condition, trace heating (steam, electrical).

4.12 SHORE ANCILLARIES - PUMPS

Note to be made of pump types, capacities, filters, hose exchanges, ship-to-shore connections.

4.13 SHORE ANCILLARIES - CONDITION

Where pumps, filters, hoses, articulated arms, are open, these should be visually inspected. Where they are connected with rigid pipework, permanent flexibles, the installation operator shall advise previous movement, probable contents.

4.14 SHORE WEIGHING FACILITIES

Include bulk weigh scales, road and rail weighbridges, package scales.

4.15 WEIGHING EQUIPMENT - ACCURACY CHECKS, APPROVALS

In countries where national bodies make periodic accuracy checks and issue approvals, evidence of this should be sought and reported. This applies to all capacities of equipment. It is possible to check small package scales with a known standard weight.

4.16 WEIGHBRIDGE OPERATION

Road and rail vehicle weighing should be checked to ensure platforms clean, scale zero prior to weighing, vehicles correctly positioned and stationary. Gross and tare weights to be recorded and copies of printed tickets to be obtained if available. Vehicle movements monitored and weight summary reconciled and reported accordingly.

4.17 WEIGH SCALE OPERATION

As with vehicle weighbridges, weigh scales should be checked to be clean, dry, free-mounting and fully draining. Observing operation and reporting as weighbridge to be above.

4.18 SMALL PLATFORM SCALES

Periodically check against known standard weight if available. Observe correct operation and record weights, obtaining printed tickets if available.

5. SHIPS PRACTICES AT LOADING AND DISCHARGE

5.1 SHIP'S TANK - FACILITIES RELEVANT TO THE PARTICULAR OPERATION

Information to be obtained from the ship of relevant ship's tanks capacity, location in vessel, construction, material, internal coating, heating facilities, suctions, stripping suctions, calibration data, ullage references.

5.2 SHIP'S TANK - FITNESS AND CLEANLINESS

Obtain information by sighting the FOSFA Combined Master's Certificate signed by the Captain/First Officer, or equivalent statement signed by the ship's owners/authorised agent, in respect of the previous three cargoes and method of cleaning after last cargo, including note of chemicals used in cleaning and whether the final rinse was performed with fresh water followed by drying.

Acceptability of tank with or without further specific testing and cleaning to be checked against current FOSFA contract terms and categorised product lists, as may be currently issued by FOSFA. Where such review requires specific testing and cleaning, this can only be progressed by the superintending organisation where specialist operatives are available and specialised laboratory facilities are close at hand. Otherwise, if tank empty and safely accessible and gas-free, inspect walls, bulkheads and bottom for cleanliness and surface condition (coated or otherwise).

Check visually so far as accessible to ensure that no internal fittings of copper or copper alloy, which are not allowed. Report on condition of tank coating. Report on residues, loose scale, hardened product adhesion to cross-members, etc. Where chemical cleaning has taken place, it is essential to check for residual chemicals. Report on any unusual foreign odour and identify if possible. Where not accessible, a very limited inspection can be made from deck manholes. If the condition of tank is unacceptable, if possible advise Principal and/or reject. The superintendent reports on the FOSFA Certificate of Compliance, Cleanliness and Suitability of Ship's Tank, based on sighting the FOSFA Combined Master's Certificate.

5.3 SHIP'S TANK - HEATING COILS

Report on layout of immersed coils or heat exchangers, construction material of coils, heating medium and determine date of last live pressure test and record as required. At completion of loading, appropriate heating instructions for oil in transit and at discharge to be drawn up, placed on board the ship and signed for and receipted on behalf of the Master. Guidelines for heating oils and fats are at Annex II.

5.4 SHIP'S TANK MEASUREMENT - GROSS DIP

Ullaging with steel tape and ullage rule is recommended. This is to be from a marked datum point related to ship's calibration data from which volume is calculated. Coincident with ullaging, note should be made of draughts, list and trim of ship and adjustment made when calculating ship's figures. As ship's calibration is generally based on builders' drawing, degree of accuracy may be limited.

5.5 SHIP'S TANK MEASUREMENT - WATER

Difficulties of measuring free water (as noted for shore tanks) apply in the case of ship's tanks, with the added problem of dipping to a known bottom and obtaining an equivalent volume from calibrations.

5.6 SHIP'S TANK MEASUREMENT - TEMPERATURE

Depending on equipment available, temperatures can be measured at various levels by electronic devices fitted with probes or by drawing up sample and measuring temperature in the sampler by hand-held thermometers, digital or liquid in glass. Under no circumstances is glass permitted inside tanks containing oils and fats.

5.7 SHIP'S PIPELINE - FACILITIES RELEVANT TO THE PARTICULAR OPERATION

In conjunction with ship's officers and drawings of pipeline system, the superintendent should ensure that he understands line routing, valve separation and segregation as far as his operation is concerned. Obtain from the ship's crew the last use of lines to be used and, with the exception of segregated tanks, lines and pumps, the previous three cargoes in the lines should be checked against current FOSFA contract terms and the FOSFA List of Banned Immediate Previous Cargoes or the FOSFA List of Acceptable Previous Cargoes.

Where accessible, inspect and ensure that they are empty and clean, including making a note of chemicals used in cleaning. Report if not accessible for inspection. Reports to be made on the FOSFA Certificate of Compliance, Suitability and Cleanliness of Ship's Tank.

5.8 SHIP'S ANCILLARIES - PUMPS

Note to be made of pump types, capacities, functions, and location - centralised pump room, submerged in tank, together with filters, suction. Pumps shall not contain copper or copper alloy. Where refined oils are shipped, preference is for tanks which have dedicated pumps. Otherwise, the pumping system should be adequately segregated from other incompatible grades, preferably by means of double valve.

5.9 SHIP'S ANCILLARIES - CONDITION

Where pump rooms permit safe access and pumps, filters, are open, these should be visually inspected. Where these are inaccessible or connected with rigid and permanent pipework, the superintendent must rely on the ship to advise previous movement, possible contents and report accordingly, including note of chemicals used in cleaning. Similarly, sea cocks should be checked where accessible. Where tanks are being loaded for voyage, tank hatches, sounding pipes, should be checked to ensure water-tight to prevent ingress of sea water during voyage.

5.10 INFORMATION AND REPORTING

Specific information must be provided by the ship's command in the form prescribed in the FOSFA publication "Carriage of Oils and Fats".

6. MOBILE TANKS - ROAD/RAIL VEHICLES, PORTABLE TANKS (UP TO ABOUT 100 TONNES CAPACITY)

6.1 MOBILE TANKS - FACILITIES

Information to be obtained from the operator of capacity, construction, materials, internal coating, insulation, heating facilities, valves and valve segregation, calibration, together with nature of mobility. Report if mobile tank not dedicated.

6.2 MOBILE TANKS - CLEANLINESS

External and internal condition, state of cleanliness, dryness visually inspected. Although requirements are generally similar to those applying to ships and shore tanks, the nature of their application, particularly road vehicle tanks, is such that they can be cleaned quickly and effectively.

6.3 MOBILE TANKS - HEATING AND INSULATION

Information to be obtained from the operator on internal coils, type, heating medium with source and method of applying, shell insulation and any external heating.

6.4 MOBILE TANKS - MEASUREMENT CONTENTS

Road and rail tanks to be measured either by gross and tare weighing or volumetrically by dip or ullage if on a level surface.

6.5 MOBILE TANKS - WATER

Where tanks are mounted with slope to end or centre or, by virtue of their mobility, can be tilted towards bottom valve off-takes, it is preferable to run off free water rather than attempt to measure.

6.6 MOBILE TANKS - TEMPERATURE

Depending on equipment available, temperatures can be measured at various levels by electronic devices fitted with probes or by drawing up sample and measuring temperature in the sampler by hand-held thermometers, digital or liquid in glass. Under no circumstances is glass permitted inside tanks containing oils and fats.

6.7 MOBILE EQUIPMENT - PIPELINES

Most mobile tanks have valved bottom outlets with short pipelines which are usually empty except when transferring which must be checked.

6.8 MOBILE EQUIPMENT - ANCILLARIES

Where vehicles have power-driven pumps to handle their loads, these are generally small with open suction and discharges which can easily be inspected. Where discharge is effected by vehicle mounted air compressor, this must be checked to ensure lubricant mist is not passing into tank. Filters should be inspected if present.

7. **SAMPLING**

7.1 GENERAL

Sampling should be in accordance with ISO 5555. Sampling requirements, points of sampling, are given in FOSFA contracts. The following are recommended in respect of equipment, method. The sampling temperatures, as set out in ISO 5555, are incorporated in the Temperature Table included in the 'Carriage of Oils and Fats' publication.

7.2 SAMPLE DEFINITIONS

Consignment - Quantity of oil delivered at one time and covered by a particular contract or shipping document. (Note - it may be composed of one or more lots or parts of lots).

Lot - Identified quantity of oil, presumed to have uniform characteristics.

Increment - Quantity of oil taken at one time from one place in a lot.

Bulk Sample - Quantity of oil obtained by combining the various increments from a lot in amounts proportional to the quantities they represent.

Laboratory Sample - Quantity of oil obtained from the bulk sample after suitable homogenisation and reduction in size, which is representative of the lot and intended for laboratory examination.

Conventional Mass Per Volume ("Litre Weight in Air") Sample - Quantity of oil taken for the mass of fat to be calculated from the volume.

7.3 SAMPLING EQUIPMENT

7.3.1 Material

For sampling instruments, stainless steel is the most suitable material. Aluminium may be used only when acidity is low. Copper, copper alloys (exposed or plated) shall not be used. Plastic sample containers, as might be used in a weighted cage sampler, should meet food contact requirements. PET is recommended but it may be subject to distortion when filled with or immersed in oils at temperatures above 50°C. If glass is used, great care should be taken to avoid breakage. Under no circumstances is glass permitted inside tanks containing oils and fats.

7.3.2 Simple Weighted Can

Cylindrical can with weighted base and conical neck fitted with bung, suspended on cord.

7.3.3 Weighted Cage for Sample Bottle

Cage weighted at base and suspended on cord. Contains a standard plastic sample bottle fitted with bung and used in similar manner to weighted can.

7.3.4 Open-Topped Valved Sampler

Heavy gauge cylindrical vessel with very light dead-weight disc valve in the base, suspended on cord.

7.3.5 Bottom Sampler

Cylindrical can, heavy gauge or weighted, with valves in base and in top on a common spindle, both opened by a plunger acting either against a light spring or dead weight, suspended on cord.

7.3.6 Sampling Tubes

Simple pipette type or concentric tubes with entry ports in outer tube which are closed by rotating the inner tube.

7.3.7 Sampling Scoops

Short, straight scoops, semi-circular cross-section, for sampling solid fats by inserting, twisting and with drawing a core sample.

7.4 CLEANLINESS

Sampling equipment must, at all times, be clean.

7.5 SAMPLING METHODS

7.5.1 Level Sampling from Shore or Ship's Tanks

Weighted sample can with bung inserted, lowered to required level, bung withdrawn, time allowed for can to fill at that level, sample drawn up. (Note - for lower depths, necessary to cut a small "vee" in bung to overcome buoyancy and enable bung to be withdrawn).

7.5.2 Sample from Vertical Cylindrical Tank

For homogenous contents, one recommendation for sampling for both quality and determination of litre weight in air is to divide tank contents into five equal layers, drawing sample material at one-tenth, one-half and nine-tenths levels and bulking them in proportion 1:3:1 representing one-fifth, three-fifths and one-fifth respectively. When contents are not homogenous, it may be necessary to draw samples at 300 mm levels, bulking them in equal proportions.

7.5.3 Sample from Ship's Tanks

Same general approach to shore tank, bulking the samples in proportion to the estimated volume of the tank above and below the mid-point at which the sample drawn.

7.5.4 Sample from Vehicle Tank Circular or Oval Section

Same general approach as above, bulking in proportion to estimated volume.

7.5.5 Bottom Sample

Bottom sampler with disc valves in base and top, on common spindle, lowered to bottom of tank until bottom valve opens admitting sample and air is released through top valve.

7.5.6 Pipeline Sample - Constant Flow (Applicable Liquid, Homogenous Oils)

From a small bore pipe set into main product flow line, adjust valve to permit constant drip and collect as sample.

7.5.7 Pipeline Sample - Intermittent Flow (Applicable Liquid, Homogenous Oils)

From a small bore pipe set into main product flow line as above or from a drain cock or similar in the line, draw sample as required.

7.6 BULKING OF SAMPLES

7.6.1 Quantities

Reference has been made above to quantities of sample from each level to be bulked to prepare a representative sample.

For contractual analysis, a sample of 250 ml is sufficient but, in case special analyses are needed, a sample of 500 ml or more may be required. Similarly, for certain specific tests, laboratories may call for samples packed in glass containers.

7.6.2 Bulking - Methods

Where climatic and other conditions permit, product remaining liquid, etc, correct proportions of sample should be placed in a clean mixing vessel, not copper or copper alloy, thoroughly mixed and distributed to sample bottles. Where such conditions do not exist, it is recommended that sample be transferred direct to bottles and removed to laboratory for liquifying of contents and homogenising.

7.7 SAMPLE PACKAGING, LABELLING, SEALING AND DISTRIBUTION

In accordance with FOSFA Official Method (Technical Manual) and specified in ISO 5555.

7.7.1 Packaging of Oils and Fats Samples

Samples for analysis or retention shall be packed in clean, dry, air-tight containers of glass or polyethylene terephthalate (PET) which should meet food contact requirements. Caps shall be screw-type, capable of forming an air-tight closure. For PET bottles, caps are normally high-density polyethylene (HDPE) which is equally suitable for glass where metal caps may still be used.

Rubber and flexible polyvinyl chloride (PVC) caps shall not be used. Metallized cardboard wads shall be used in caps but they must not contain copper, copper alloy, zinc or iron. Sample containers shall be almost, but not quite, filled. A little air space shall be allowed at the top for expansion. This space should not be too large as air exerts a detrimental action on most oils. In order to avoid deformation of PET bottles at oil temperatures above 50°C, it is suggested that after filling with oils above that temperature, the oil is allowed to cool below 50°C before the cap is finally tightened and, similarly, when liquifying by raising the temperature above 50°C, the cap should be loosened slightly. All samples should be protected from light and heat and stored under clean, dry conditions.

For transportation, glass sample containers should be protected with a plastic foam sleeve. All sample containers should be surrounded by absorbent material such as sawdust or vermiculite, which would absorb the total contents of the container. The whole packed in a strong rigid outer container. The packaging should meet the requirements of the postal authorities or other organisations involved in the transport of the sample in the country or countries involved.

7.7.2 Labelling

Labels are usually of adhesive-backed paper or tie-on card capable of being securely affixed directly to the sample bottle or to the bag within which it is contained and must be strong enough for the purpose. It should include full identification details, reference number, origin and documentary reference, sampling details, etc, and this should be recorded with a permanent marker.

7.7.3 Sealing

Where possible, caps should be security sealed to the sample bottle by means of matching tags and conventional security seals, preferably incorporating the tie-on label when used. Where this is not possible, the sample bottle would normally be placed within a plastic bag which itself may be security sealed by an appropriate method.

7.7.4 Distribution

Samples should be distributed in accordance with the relevant FOSFA contract requirements.

PAGES 13-19 ARE DELIBERATELY OMITTED

CHECK LIST FOR OPERATIONS - OILS AND FATS

CHECK LIST AT LOADING

Typical operation of loading water-borne vessels from shore sources.

1. BEFORE LOADING

1.1 EX-SHORE

Shore Tanks - Allocation, dip, gross, water, temperature, sample.
Through Weigh Scales - Empty, clean, free mounting.
Ex-Road/Rail Vehicles - Weigh or dip, water, temperature, sample.
Shore Facilities - Pipelines - routing, segregation, contents, pigging.
Pumps - capacity, segregation, condition.
Flexibles - suitable condition.

1.2 INTO SHIP

Ship's Tanks - Allocation, capacity, previous cargo, cleaning, contaminants review, inspection, cleanliness and fittings, coils.
Ship's Facilities - Pipelines, pumps, sumps - allocation, position, segregation, condition. Sea cocks shut, sealed.
Ship's State - Draught, trim, list.

2. DURING LOADING

2.1 AT LOADING

Quality product at jetty head, first pumpings, consistent. Log events. Quantity into ship reconciled ex-shore tanks, loading rate. Change over tanks, topping up.

2.2 ON SHORE

Quantity ex-shore tanks, heating, stripping.

3. AFTER LOADING

3.1 AT SHIP

Ship's Tanks - Ullage, water, temperature, sampling, ship's figures.
Ship's Facilities - Clear lines, seal valves, hatches.
Ship's State - Draught, trim, list.
Ship's Documents - Heating instructions, ullage reports. Shipping samples. Ship's Officers to acknowledge receipt by signature of heating instructions, samples.

3.2 ON SHORE

Shore Tanks - Inspect empty or dip gross, water temperature - provisional/final.
Calculate delivered quantity.
Shore Facilities - Pipelines, pumps, flexibles, empty or condition.
Notes of Protest - Lodge in respect of loss, damage, delays, stoppages.

CHECK LIST AT DISCHARGE

Typical operation of discharging ships to shore or to water-borne craft.

1. BEFORE DISCHARGE

1.1 INTO SHORE

Shore Tanks - Allocation, capacity. If empty - previous contents, cleaning, inspection cleanliness and fittings, coils. If part-filled, dip gross, water, temperature, sample.
Barge Tanks - Allocation, number and capacity, suitable, inspection cleanliness and fittings, coils.
Vehicle Tanks - Allocation, number and capacity, suitable, inspection cleanliness and fittings, coils.
Shore Facilities - Pipelines - routing, segregation, contents, etc., pigging. Flexibles - suitable, condition.

1.2 EX-SHIP

Loading and Transit Details - Port, draughts, etc, ullages, ship's figures. Heating log, samples, documents, etc. Inter-tank transfers.
Ship's State - Arrival - Draught, trim, list.
Ship's Tank - Arrival - Allocation, ullage, water, temperature, sampling, ship's figures, compare loaded/arrival.
Ship's Facilities - Arrival - Valves, sea cocks, hatches, secure and sealed. Pipelines - allocation, position, segregation, condition. Pumps - allocation, capacity, segregation, condition.

2. DURING DISCHARGE

2.1 AT SHIP

Condition at jetty head, log events, quantity ex-ship's tanks, discharge rate, stripping tanks.

2.2 ON SHORE

First pumpings into tank, consistent quality tank side. Quantity into shore reconciled ex-ship, change-over shore tanks, topping up.

3. AFTER DISCHARGE

3.1 AT SHIP

Ship to Shore Connections - Cleared and drained.
Ship's Tanks - Inspect empty, estimate residues. If part-discharged, ullage, water, temperature.
Ship's Facilities - Pumps, lines, empty.
Ship's State - Draught, trim, list.

3.2 ON SHORE

Shore Tanks - Dip, water, temperature - provisional/final. Calculate receipt, sample.
Shore Facilities - Pipelines, flexibles, empty or condition.
Notes of Protest - Lodge in respect of loss, damage, delays, stoppages.

GUIDELINES FOR HEATING OILS AND FATS

(Reference to oil implies oils and fats).

1. Reasons for Heating

It is necessary to apply artificial heating to some oil products to ensure homogeneity for sampling and delivery when the oil must be liquid with no fat solids or crystals and not be temperature/density layered. Heating will accelerate precipitation of moisture. Heating may be required to reduce viscosity to acceptable pumpable levels.

2. Contracts, Standards

Where FOSFA contracts either contain specific instructions or refer to recommendations of named bodies, these should be applied. These are generally concerned only with ship's tanks at loading, during voyage and at discharge. Additionally, some national and international standards recommend temperatures for specific products, principally for sampling.

3. Guidelines

Where the contract does not provide temperature and heating recommendations or provides only for ship's tanks, then the following guidelines are suggested. When heating is applied to immersed coils, use either hot water passing through the heating coils (providing these are self-draining) or low pressure saturated steam at maximum pressure 150 kPa/1.5 bars, limiting coil surface temperatures to about 128°C in order to prevent local burning. Alternative heating may be applied through heat exchangers with similar restrictions on heating media and temperature control. Heating should be applied such that average oil temperature increases at a rate of not more than 5 degrees C in a 24 hour period. It shall not be considered that the product is evenly heated if the difference between the top and bottom temperatures in the tank exceeds 5 degrees C. Temperatures should be maintained within the recommended ranges to ensure homogeneity at the lower end and to avoid over-heating, oxidation, etc, of the oil at the upper end. Of necessity, any tabulated recommendations must be of a general nature. Where oils are known to have different characteristics, the heating levels must be adjusted accordingly.

4. Heating Instructions in Respect of Bulk Shipments

The FOSFA Heating Instructions referred to in many contracts are included in the 'Carriage of Oils and Fats' publication, as revised from time to time. These include a table of heating recommendations for the maximum and minimum temperatures for oils and fats both in transit and at discharge.

THIS PAGE IS DELIBERATELY BLANK

INFORMATION TO BE GIVEN ON CERTIFICATES - OILS AND FATS

STANDARD REQUIREMENTS

1. Superintendent's logo.
2. Name and address of superintendent.
3. Certificate number.
4. Date and place of issue.
5. Description of certificate (weight, quality).
6. Name of Principal.
7. Summary of Principal's instructions.
8. Description of consignment -
 - a. Transfer from other conveyance -
 - i. From.
 - ii. To.
 - b. Number of packages (or bulk).
 - c. Type/description of packages (if any).
 - d. Mark on packages (if any).
 - e. Declared weight.
 - f. Commodity (as declared).
 - g. FOSFA contract number (if known).
9. Findings (depending on mandate) such as -
 - a. Tank inspection.
 - b. Sampling.
 - c. Weighing (also certifying ship's tanks measurements, ullages, soundings, temperatures, vessel's draught (fore and aft), list and trim).
 - d. Loading.
10. Date and Place of Intervention.
11. Signature.

ADDITIONAL/OTHER REQUIREMENTS

1. Names of Buyers/Sellers.
2. Additional findings.
3. Cleanliness inspection of ship's tanks -
 - a. Specify tanks inspected.
 - b. Certify condition of tanks.
 - c. Certify condition of pumps and lines.
 - d. Result of tightness tests carried out (supervision of superintendent).
 - e. Condition of tank coatings.
 - f. Date, time and place of inspections.
4. Details of ship's draught survey (if any).
5. Details of barge calibrations.
6. Sampling -
 - a. Number of samples drawn and sealed.
 - b. Details of seals.
 - c. Distribution/disposal of samples.
7. Supervision of weighing -
 - a. Type and description of scales.
 - b. Weight (ascertained or calculated).

8. Other findings, such as -
 - a. Quality/condition of the oil (analysis and by whom carried out).
 - b. Quality/condition of packages.
 - c. Method of loading (from/to landtanks, road/rail, tank cars, barges (including over the top).Details of co-mingling with other parcels (if any).
 - d. State of shore and ship's lines before and after loading (full/empty).
9. Details of seals (if any) on valves and manhole covers.
10. Reference to loss/damage during loading.
11. Reference to heating instructions.
12. Timelog of loading operations.

DISCHARGE REPORTS/CERTIFICATES

As far as applicable, use the same presentation as above in issuing discharge reports in which the following additional findings may be of particular interest to parties concerned, especially so in case of damage or abnormally high shortage.

1. Ship's tank ullages/soundings and temperatures prior to discharge.
2. Vessel's draught (fore and aft), list and trim.
3. Corresponding weight on board, taking into account due corrections for vessel's trim and list.
4. Whether tanks, valves were found to be sealed or not.
5. Method of discharge.
6. Details of puddling/sweeping carried out.
7. Quantity of sweepings recovered/sampled separately (if any).
8. Quantities remaining on board (as estimated jointly with receivers'/carrier's representatives).
9. State of ship's/shore lines before and after completion of discharge (full/empty).
10. Details of disposal of damaged oil.
11. Condition of oil.
12. Condition of packages.

Furthermore -

13. Prorata details (if any).
14. Reference to loss/damage in transit or discharge.
15. Reserves made by superintendent (or receiver).



FOSFA
INTERNATIONAL

OILSEEDS (PART 2)

1. **GLOSSARY OF TERMS**

This glossary of terms is for use in the Oilseeds Section/International Trade of Oilseeds.

Admixture/Impurities - All foreign matter, organic and inorganic, other than seeds of the species under consideration.

Bag Tally - Count of bags passing over ship's rail at loading or discharging.

Cargo Sweat - Condensation formed on the cargo when its temperature is below the dew point of the air surrounding it.

Dunnage - Mostly timber, on floors and sides to protect cargo from moisture, etc, provide air courses, secure cargo where stowage voids spread compression load, etc, separate different cargoes or lots.

Fines - The particles passing through the sieves (aperture sizes shown in Table 1 of ISO 658 - Oilseeds - Determination of Impurities), according to the species being analysed.

Fumigation - Application of a chemical (in gaseous form) to a bulk of oilseeds (in silos, elevators, trucks, rail cars, barges and ships) in order to kill pests.

Fumigation Agent - A chemical formulation which has been made up as a pesticide or post-harvest spray. It is used to kill animals which are eating the oilseeds or which are poisonous or producing poisonous materials.

Hook Damage - Damage to hessian (jute or hemp) or polypropylene sacks containing oilseeds from stevedores' hooks.

Infestation - Contamination and/or damage resulting from presence of certain live pests such as beetles, moths and mites, as well as caterpillars, cocoons, pupae, maggots and eggs.

Inherent Vice - Certain commodities such as oilseeds may be expected to suffer weight loss during transit due to natural causes such as loss of moisture content. This fact needs to be taken into account when assessing shortages. Conditions conducive to the drying of the oilseeds commodity will cause it to lose weight, whereas humidity will cause it to absorb moisture and so gain in weight. The possibility of a natural or non-fortuitous loss is present with most vegetable matter, particularly oilseeds or oilseeds shipped in sacks or bags. Bulk oilseed cargoes may be subject to a small loss between shipped and delivered weights.

The term "inherent vice" is frequently used to describe the cause of damage or loss coming from within a commodity itself. These causes may include living organisms, e.g. insects, mites, bacteria and moulds, through whose activity heating, putrefaction and moulding result. Care must be taken in attributing such damage to inherent vice and an expert should be employed if there is the slightest reasons for doubt as to the true cause of the damage.

Mould - Oilseeds (and indeed most organic materials) are subject to attack by micro-organisms if their moisture content rises above a certain minimum. These micro-organisms are mainly bacteria and fungi (including yeasts and mould).

Phyosanitary Certificate - An official government certificate from the origin shipper of the oilseeds and is issued by an official Plant Inspection Department of the shipper's government. An example of a Phyosanitary Certificate is shown at Appendix IV.

Ship's Sweat - Condensation formed on the walls of the hold when the temperature of the

walls falls below the dew point of the air inside the hold.

Tally Schedule - Bagged Cargoes - A superintendent's official record which is used as evidence to support the tally, counting arrangements and timing record for the loading and discharge of bagged oilseed cargoes.

Weighbridge Weighing (Road Trucks and Rail Cars) - Weighing on a calibrated and certified weighbridge of empty and loaded vehicles on the same scale under comparable conditions.

2. FUNCTIONS OF SUPERINTENDENTS

2.1 GENERAL

To act on his Principal's instructions in a professional manner, performing in person those operations required of him, observing conduct of operations by others and protecting the interests of his Principal. The superintendent should report any departures from normal and/or specified practice to his Principal.

2.2 CONTRACT PARTIES

Within FOSFA contracts, a superintendent may be appointed by either Buyer, Seller or both.

2.3 SCOPE OF INTERVENTION

Must be fully acquainted with the relevant FOSFA contract terms, remaining within these, not assuming responsibilities which are not covered by his instructions.

2.4 AUTHORISATION

Following upon 2.2 and 2.3 above, the other contractual party and other interested parties (such as authorities, installations, vessels or Buyers and Sellers in a string) must be advised in detail of the nomination of, and requirements delegated to, the superintendent.

2.5 RESPONSIBILITY

The Principal must accept the immediate and consequential effects and costs to all involved parties of the superintendent's intervention on his behalf.

2.6 MAIN OPERATIONS

2.6.1 The superintendence of loading or discharging of ships, barges, river craft, lorries, trailers or railway wagons, including the reporting of facilities available, inspection of the vessel holds and hatches for cleanliness, measurement of quantities, sampling for the presence of moisture, impurities and quality, as specified in the contract or advised by his Principals. The vessel holds and hatches for oilseeds must be totally clean from the previous cargo.

The superintendent should report on the availability of dunnage when it is intended to load the goods packed in bags. Inspection of the vessel's holds and hatches for their condition and a statement from the Chief Officer on the previous cargoes is required, as well as a measurement of the quantity of oilseeds contained in the hatch, barge, railway wagon or lorry.

2.6.2 Issue survey reports as called for under the relevant contract and/or local and international legislation. Information to be given on survey reports/certificates is set out in Annex II

3. OPERATING PRACTICES

3.1 CONDITIONS

As considerable variation of conditions exist under which the superintendent may have to undertake his work, the following practices can only be applied where conditions permit.

3.2 GENERAL PRACTICE

The Code effectively constitutes recommendations for the performance of operations which are basically similar for loading and discharging and may generally be applied to storage, transportation and handling equipment without significant change for the type and size of that equipment.

3.3 PARTICULAR PRACTICE

Included within Part Two of this Code is a Check List (Annex I) for typical loading and discharging operations of oilseeds to assist the superintendent in following the sequence of the particular operation. In addition, an informative Annex on damage and contaminated oilseeds is at Annex III.

4. SHORE PRACTICES AT LOADING AND DISCHARGE

4.1 BULK TO BULK HANDLING OF OILSEEDS

The superintendent should report if "grab" loading or discharge is taking place and ascertain whether the "grabs" and shore loading or discharging facilities are serviceable. Spillages of oilseeds onto the quay and on the deck of the ship should be requested by the superintendent to be recovered (provided that they are in sound condition and not damaged) and added to the bulk.

4.2 WEATHER

The superintendent should report on the condition of the weather at the time of loading/discharge and record in his log if high winds, rain or snow took place during loading/discharge.

4.3 BAGS TO BULK

The superintendent, when supervising bags to bulk, must ascertain that a system is in operation that prevents the leaving of bags in the vessel's hold. Where bags are loaded to act as a retaining wall, no slack, torn or leaking bags are to be loaded.

4.4 SHORE WEIGHING FACILITIES

Include bulk weigh scales, road and rail weighbridges, package scales.

4.5 WEIGHING EQUIPMENT - ACCURACY CHECKS, APPROVALS

In countries where national bodies make periodic accuracy checks and issue approvals, evidence of this should be sought and reports made accordingly. This would apply to all capacities of equipment but, over and above this, it is sometimes possible to check small package scales with a known weight at that particular weight.

4.6 WEIGHBRIDGE OPERATION

Road and rail vehicle weighing should be checked to ensure platforms are clean, scale at zero prior to weighing, vehicles correctly positioned and still. Gross and tare weights to be recorded and copies of printed tickets to be obtained if available. Vehicle movements monitored and weight summary reconciled and reported accordingly.

4.7 WEIGH SCALE OPERATION

As with vehicle weighbridges, weigh scales should be checked to be clean, dry, free mounting and complete emptying. Observing operation and reporting as weighbridge (see 4.6).

4.8 SMALL PLATFORM SCALES

Periodically check against known standard weight if available. Observe correct operation and record weights, obtaining printed tickets if available.

4.9 SUCTION/VACUUM LOADING BULK TO BULK

This operation normally takes place at major oilseed bulk terminals and the superintendent should ask to see the control apparatus, which is normally a computer controlled test run. He should also receive a print-out from the automatic weighing apparatus and, where necessary, have a test run conducted to verify the findings. If the test run differs from the print-out, then the superintendent should ask for the test to be run again under his supervision.

4.10 BELT WEIGHING

Where the Superintendent is instructed to apply belt weighing, he shall -

- 4.10.1 Ask his principal for confirmation of the agreement between the contract parties to apply belt weighing;
- 4.10.2 Verify that the weighing instrument has a valid calibration certificate issued by a competent calibration agency or authority;
- 4.10.3 Check that the loading/discharge operations are continuous and ensure that they are accurately recorded (variations to be noted); and
- 4.10.4 Clearly state on the Certificate of Weight that belt weighing has been applied together with the confirmation of the proper application of 4.10.1, 4.10.2 and 4.10.3 above.

4.11 DRAFT SURVEY

Where the Superintendent is instructed to apply draft survey, he shall -

- 4.11.1 Ask his principal for confirmation of the agreement between the contract parties to apply draft survey;
- 4.11.2 Clearly state on the Certificate of Weight that draft survey has been applied, in the absence of both discontinuous and continuous automatic weighing instrument(s), together with the confirmation of the proper application of 4.11.1 above.

5. **SHIPS PRACTICES AT LOADING AND DISCHARGE**

5.1 SHIP'S HOLDS AND HATCHES

Check by visual inspection that the holds and hatches are clean and dry. Ascertain what evidence exists concerning the previous cargo from the Chief Officer's log. When checking the sides of the ship's hold and hatch, flaking paint should be checked for residual evidence of cargo, as well as evidence of infestation (rodent and insect). Note to be made of sufficient dunnage available to the operation when goods are loaded packed in bags.

5.2 SHIP'S HOLDS AND HATCHES - FUMIGATION

The superintendent should observe and report when fumigation is carried out.

5.3 SHIP'S HOLDS AND HATCHES - FACILITIES

At discharge the superintendent must assess the condition of the cargo and report on any unusual occurrences, such as sweating, heating, undue odour or the presence of sea water or oil.

6. **SAMPLING**

6.1 GENERAL

Sampling should be in accordance with the contractual methods as laid down in the FOSFA Technical Manual. Sampling requirements and points of sampling are given in FOSFA contracts.

The number of contract samples to be drawn for analysis and arbitration are specified in the relevant contract or otherwise agreed between Buyer and Seller. All contract samples must be sealed. For some seeds, it is advisable to screen the bulk sample before dividing and then to add the fines to the contract samples in the correct proportion. This is to ensure that the samples contain the same percentage of low-quality fines.

6.2 SAMPLE DEFINITIONS

Consignment - The quantity of oilseed dispatched or received at one time and covered by a particular contract or shipping document. It may be composed of one or more lots or parts of a lot.

Lot - A stated quantity of the consignment, which in itself is presumed to be of uniform characteristics, and which will allow the quality to be assessed.

Increment - A small quantity of oilseeds taken at one time from a single position from a stationary lot, or taken throughout the moving lot. A series of increments is taken from different parts of the stationary lot, or throughout the moving lot, so that when they are bulked, they are representative of the lot.

Bulk Sample - The quantity of oilseeds obtained by combining and blending the increments taken from a stationary lot or throughout a moving lot.

Laboratory Sample - Representative quantity of oilseeds obtained by division of the bulk sample and intended for analysis or other examination.

6.3 SAMPLING EQUIPMENT

6.3.1 Sampling Equipment

Sampling equipment should be clean, serviceable and dry before use. It should not be used for any other purpose but oilseed sampling.

6.3.2 Sample Equipment Diagrams

Diagrams of equipment such as sampling spear (open trier), hand scoop, divided sampling spear (open trier), cylindrical sampler (divided bulk probe), running iron (sack-type trier), falling stream sampler (pelican type, quartering irons, conical divider (Boemer type) and a multiple-slot divider can be found in ISO 542 - Methods for Sampling Oilseeds.

6.3.3 Sampling from Bags - Equipment

Samples will be taken using sack-type spears or triers, cylindrical or conical samplers or hand scoops.

6.3.4 Sampling from Bulk - Equipment

Unless effected by approved mechanical samplers, samples will be taken using shovels, hand scoops, cylindrical samplers or other apparatus for drawing small periodical samples from the bulk of the oilseed while undergoing transfer. Sampling shall be effected at nearest point to the ship concurrently with the loading or discharging operations.

6.3.5 Mixing and Dividing Samples

Samples will be divided using shovels, quartering irons and other dividing apparatus.

6.4. LIMITATION OF THE SIZE OF THE LOT

6.4.1 Ship

Most oilseeds are received from ocean-going vessels or from river transport. In both cases, sampling normally takes place at transfer from the vessel. Lot sizes are given in the contractual sampling method as laid down in the FOSFA Technical Manual.

6.4.2 Road or Rail

In the case of transfer from vessel to road or rail wagons, sampling may take place prior to the loading of the wagons. If sampling is carried out from laden wagons, each wagon/truck should be sampled and each lot should comprise a number of wagons/trucks containing the lot quantity or part thereof.

6.4.3 Silo or Warehouse

Where seed is unloaded direct to silos or warehouses from a ship, the samples should be drawn as in Clause 6.4.1. Where there is no provision for such sampling, this may take place prior to, or during, transfer to silo or warehouse. Lot sizes are given in the contractual sampling method as laid down in the FOSFA Technical Manual.

6.5 METHOD OF DRAWING SAMPLES

6.5.1 General

Sampling should be carried out by superintendents appointed by Buyers and/or Sellers. As the composition of the lot is seldom uniform, a sufficient number of increment samples should be drawn to provide a representative bulk sample. Seed which is sea damaged or otherwise damaged in transit or out of condition, as well as loose collected and sweepings, should be sampled separately from the sound seed. The damaged material should not be blended with the sound material but should be assessed and quantified separately.

6.5.2 Drawing of Increment Samples

According to circumstances, the samples should be drawn from products in bulk or in bags by means of sampling equipment.

6.5.3 Increment Samples - Bags

Incremental samples should be drawn from not less than 2% of the bags forming the lot with a minimum of five bags. When the bags are opened, they should be emptied, whereupon the increment samples may be drawn by hand scoop. When samples are drawn from the closed bags, sack-type samplers may be used, provided not less than 2% of the number of bags are sampled.

6.5.4 Bulk Flow Sampling

When sampling takes place while the product is in motion, increment samples should be drawn throughout the whole section of the seed and at time intervals dependent on the rate of flow. When bulk seed is sampled in the holds of ocean-going vessels or craft or lash- barges during discharge, increment samples should be drawn from as many places as possible and at intervals determined by the rate of discharge.

6.5.5 Open-Top Containers and Box Cars

If sampling takes place from laden wagons, increment samples should be drawn at three levels with a cylindrical sampler or conical sampler, depending on the seeds, from the following number of points -

Wagons or lorries up to 15 tonnes	5 sampling points
Wagons from 15-30 tonnes	8 sampling points
Wagons from 30-50 tonnes	11 sampling points

6.5.6 Hopper-Cars and Containers

Where seed is carried in hopper-cars and/or containers, these should be sampled during loading or discharge.

6.5.7 Sampling from Weigh Scales

If sampling takes place from weigh scales, increment samples should be drawn by means of cylindrical samplers, shovels or mechanical samplers in accordance with the practice of the port.

6.6 BULKING OF LABORATORY SAMPLES

On receipt of the laboratory samples, the analyst should aggregate and divide down to the

required number of test samples by use of apparatus referenced in ISO 664.

6.7 SIZE OF SAMPLES

The size of sample must allow for all relevant analyses and quality assessments to be carried out. When large sized impurities are present which are difficult to distribute homogeneously, larger sized samples should be used for all analyses. The size of the lots and the number and size of samples for oilseeds consignments are given in the contractual sampling method as laid down in the FOSFA Technical Manual.

6.8 SAMPLE PACKAGING LABELLING, SEALING AND DISTRIBUTION

6.8.1 Packaging of Oilseed Samples

Samples of all oilseeds (other than copra, palm kernels and other lauric materials) sent to laboratories for analysis should be packed in water-tight plastic jars with screw caps of the same material or in glass jars with plastic screw caps, of not less than 500 ml, which shall be filled to the top and sealed. The samples shall be stored at not more than 20°C. Certain oilseed samples such as copra, palm kernel, illipe and sheanuts should be cold stored at minus 15°C. In any case, where the sample is not packed and stored in accordance with this recommendation, the oil content at re-test should be adjusted in relation to the variation in moistures between the original test and the re-test.

For Philippine copra drawn under the terms of Contact No 1, the packaging of samples should be in accordance with the rules set down in the instructions for samples at port of discharge and for analysis of samples. Copra samples drawn under the terms of Contract No 2 should be packed in jute, linen or cotton bags. Bags of plastic sheet must not be used. Such samples should be no less than 10 kg in weight.

6.8.2 Moisture Determination

If a moisture content determination is to be carried out, a second sample shall be drawn and packed in air-tight container (preferably a plastic jar). The size of this second sample will vary according to the commodity as follows -

Illipe, shea and cashew nuts	1 kg (minimum)
Palm kernels, sunflower seed, groundnuts, cotton seed	0.5 kg (minimum)
Soyabeans, rapeseed, linseed, nigerseed, kardiseed, safflowerseed	250 g (minimum)

6.8.3 Labelling

If paper labels are used for oilseed samples, it is recommended that their quality and size should be suitable for the purpose. The eyelet hole in the label should be reinforced. The information on the labels should include at least the following detail -

Name of Superintendents/Agents

Ship's Name Hold Number

.....

Port/Date of Loading

Port/Date of Discharge

Commodity Origin

Bills of Lading No

Month of Shipment

Sample Marks

Contract Tonnage

Tons Bag Quantity

Contracting Parties

Sampled on Behalf of

Contract Body FOSFA

Contract Number

Purpose of Sample

Date

Notes

- i. It is important that Principals' instructions to superintendents make it quite clear whether the samples are being drawn for analysis and arbitration purposes.
- ii. Labels should be completed in legible hand-writing, preferably in capital letters, or typed. Labels should be securely attached to the samples they represent.

The recorded information on the label must be permanent and sealed to prevent destruction by water.

6.8.4 Sealing

Where possible, caps should be security sealed to the sample jar by means of matching tags and conventional security seals, preferably incorporating the tie-on label when used.

Where this is not possible, the sample bottle would normally be placed within a plastic bag which itself may be security sealed by an appropriate method.

6.8.5 Distribution

Laboratory samples should be dispatched as soon as possible but within 48 hours after sampling has been completed in accordance with the relevant FOSFA contract requirements.

6.9. SAMPLING REPORT

If a sampling report is requested, it should indicate the condition of the seed sampled, the technique applied and all circumstances that may have influenced sampling.

If a Radioactivity Certificate is required it is to be attached to the sampling report.

PAGES 29-35 ARE DELIBERATELY OMITTED

CHECK LIST FOR OPERATIONS - OILSEEDS

CHECK LIST AT LOADING

Typical operation of loading water-borne vessels from shore sources.

1. BEFORE LOADING

1.1 BEFORE SHIP'S ARRIVAL

Locate goods and carry out a superficial inspection of the cargo.

1.2 UPON SHIP'S ARRIVAL

Verify nature of previous cargo(es).

Check cleanliness of holds and hatches and their suitability for fumigation purposes (if applicable).

Check cleanliness of loading equipment.

Request collection/elimination of residues of previous cargo(es), if any present.

Carry out final inspection of holds and hatches and loading equipment.

2. DURING LOADING

2.1 SUPERVISION OF WEIGHING

Check the weighing installation/scales.

Exercise a regular control of the weighing operations.

Request recovery of all loose material/spillages in sound condition in warehouse, on quay and on ship's deck.

If bagged cargo is shipped in bulk, supervise the bleeding of the bags in the ship's holds.

Weigh empty bags and calculate the net weight loaded.

If weighing is via weighbridge, check tare of vehicles.

If belt weighing is used, check agreement to use this method from Principal, calibration of instrument and that loading/discharge was continuous and accurately recorded.

If draft survey is used, check agreement to use this method from Principal.

Check movement of vehicles during operation.

Check cleanliness of weighbridges.

2.2 SUPERVISION OF LOADING

Check that all goods are loaded and check that all vehicles (including lighters) are empty.

Check handling equipment for possible inadequacies.

Record and report weather conditions.

Ascertain where possible and report on loss/damage to cargo during loading operations.

Ascertain where possible and report on who is responsible for loss/damage and lodge letters of reserves.

2.3 STOWAGE CONTROL

Check and report where cargo is stowed for each commodity, consignment, lot, shipper, etc.

Check and report on separations (if any).

2.4 QUALITY INSPECTION

Sampling to be effected according to sampling rules or Principal's instructions.

Compose required number of samples and sealing of samples.

Inspect goods for presence of live weevils, insects, etc, and report.

3. AFTER LOADING

Attend the fumigation operations (if any) and complete reports.

CHECK LIST AT DISCHARGE

1. BEFORE DISCHARGE

1.1 BEFORE SHIP'S ARRIVAL

Contact parties concerned (Buyers, receivers, ship's agent).
Study loading details and compare with instructions.

1.2 UPON SHIP'S ARRIVAL

Carry out a general inspection of holds and hatches, stowage and cargo condition.
Check cleanliness of discharge equipment.

2. DURING DISCHARGE

2.1 SUPERVISION OF WEIGHING

Check the weighing installations/scales.
Exercise a regular control of the weighing operations.
If weighing is via weighbridge, check tare of vehicles during operation.
If belt weighing is used, check agreement to use this method from Principal, calibration of instrument and that loading/discharge was continuous and accurately recorded.
If draft survey is used, check agreement to use this method from Principal.
Check movement of vehicles during operation.
Check cleanliness of weighbridge.
Check the correct delivery of consignment/lots.
Count/tare stowage bags (if any) and see to it that their weight is added to the delivered weight.
Tally the bags if cargo has been shipped bagged.

2.2 SUPERVISION OF DISCHARGE

If there is damaged cargo, ascertain it and classify it separately.
Check that all loose merchandise and sweepings are weighed and delivered.
Check that holds and hatches and quay are empty after discharge.
Open bilges, feeding boards, etc, to check that no cargo remains on board the ship.
Record and report weather conditions.
Address letters of reserves to carriers and their agents in case of missing packages and/or damaged cargo.

INFORMATION TO BE GIVEN ON CERTIFICATES - OILSEEDS

STANDARD REQUIREMENTS

1. Superintendent's logo.
2. Name and address of superintendent.
3. Certificate number.
4. Date and place of issue.
5. Description of certificate (weight, quality).
6. Name of Principal.
7. Summary of Principal's instructions.
8. Description of consignment -
 - a. Transfer from other conveyance -
 - i. From.
 - ii. To.
 - b. Number of packages (if any).
 - c. Type/description of packages (if any).
 - d. Condition of stowage bags (if any).
 - e. Mark on packages (if any).
 - f. Declared weight.
 - g. Commodity (as declared).
 - h. FOSFA contract number (if known).
8. Findings (depending on mandate) such as -
 - a. Hold/hatch inspection.
 - b. Sampling.
 - c. Weighing.
 - d. Loading.
9. Date and place of intervention.
10. Signature.

VARIABLE REQUIREMENTS

1. Names of Buyers/Sellers.
2. Additional findings -
3. Cleanliness inspection of ship's holds and hatches -
 - a. Specify holds inspected.
 - b. Certify condition of holds/hatches.
 - c. Certify and report on excessive dust.
 - d. Certify and report on live infestation or mould.
 - e. Report on presence of water or the ingress of water.
 - f. Report on foreign matter (stones, metal, dirt).
 - g. Date, time and place of inspections.
4. Sampling -
 - a. Number of samples drawn and sealed.
 - b. Details of seals.
 - c. Distribution/disposal of samples.
5. Supervision of weighing -
 - a. Type and description of scales (state clearly the method of weighing which was used).
 - b. Weight (ascertained or calculated).
6. Other findings, such as -
 - a. Quality/condition of the seed (analysis and by whom carried out).
 - b. Quality/condition of packages.
 - c. Method of loading (direct from silos, lorries, barges, via lorries, barges, pneumatic or belt conveyors).
 - d. Details of commingling with other parcels (if any).

7. Reference to loss/damage during loading, abnormal weather conditions to which cargo has been exposed.
8. Timelog of loading operations.
9. Details of fumigation procedure (if any).

DISCHARGE REPORTS/CERTIFICATES

As far as applicable, use the same presentation in issuing discharge reports in which the following additional variable findings may be of particular interest to parties concerned, especially so in case of damage or abnormally high shortage.

1. Whether fumigation carried out before discharge.
2. Method of discharge.
3. Loss on discharge.
4. Details of sweepings carried out. Quantity of sweepings, damaged cargo and location/sampled separately.
5. Quantity of sweepings recovered/sampled separately (if any).
6. Quantities remaining on board (as estimated jointly with receivers'/carrier's representatives).
7. State of ship's/shore conveyors before and after completion of discharge (full/empty).
8. Details of disposal of damaged cargo, if known.
9. Condition of seed.
10. Condition of packages.

Furthermore -

11. Prorata details (if any).
12. Reference to loss/damage in transit or discharge.
13. Reserves made by superintendent (or receiver).

APPENDICES - TYPICAL CERTIFICATES

- Appendix I Certificate of Weight.
Appendix II Surveyors Report on Times/Time Sheet.
Appendix III Certificate of Cleanliness of Holds - Oilseeds.
Appendix IV Phytosanitary Certificate.

LETTERHEAD/LOGO

Certificate No *****
Date *****

TYPICAL CERTIFICATE OF WEIGHT

Container No:
Bill of Lading No: *****
Bill of Lading Date: *****
Load Port: *****
Destination: *****

THIS IS TO CERTIFY

that we, ***** *Note 1*
did proceed to the plant of: ***** *Note 2*
at: *****
on: *****

and subsequent ***** day(s) for the purpose of ascertaining the weight of a parcel of:
commodity origin: ***** oilseed in
bulk which was delivered to motor vessel: *****

The material in question was delivered ex-silo
under our supervision, the total weight being: ***** metric *Note 3*
which quantity was actually shipped on board the above vessel.

The method used for the weighing was *****

We certify the weight as: ***** metric *Note 3*

Our findings are valid at time and place of intervention only.

Authorised Signatory: ***** *Note 4*

Notes

1. Name of superintending company.
2. Description of supplier, place of loading (dock, wharf), warehouse and name of trading company.
3. The weight of the cargo loaded has to be shown in units prescribed in the contract (metric tonnes, kilos, pounds).
4. FOSFA Member Superintendent's full name and address details.

LETTERHEAD/LOGO

 Certificate No *****
Date *****

TYPICAL SURVEYOR'S REPORT ON TIMES/TIME SHEET

Vessel: *****	Load: *****
Date: *****	Discharge: *****
Port/Place: *****	Lightering: *****
Terminal: *****	Product/Cargo: *****

		Date dd.mm.yy	Time	Remarks
*	End of sea-passage			
*	Pilot on board			
*	Notice of readiness tendered:			
	Vessel arrived at: ***** (First line)			
	Notice of readiness received			
	Vessel berthed alongside installation: (all fast)			
	Deballasting: Commenced Date: Time: Finish:			
	Cargo-/Hold inspection on board by ***** inspector started:			
	Cargo-/Hold inspection on board by ***** inspector finished:			
	Commenced Discharge ... Loading ... X			
	Stoppage: ... From: Date: 00.00.00 Time: 00.00 Till			
	Stoppage: ... From: Date: 00.00.00 Time: 00.00 Till			
	Stoppage: ... From: Date: 00.00.00 Time: 00.00 Till			
	Stoppage: ... From: Date: 00.00.00 Time: 00.00 Till			
	Stoppage: ... From: Date: 00.00.00 Time: 00.00 Till			
	Stoppage: ... From: Date: 00.00.00 Time: 00.00 Till			
	Stoppage: ... From: Date: 00.00.00 Time: 00.00 Till			
	Completed Discharge ... Loading ... X			
	***** loaded hold-inspection on board finished.			
	Documents on board			
	Vessel sailed from Berth (etc)			

Times marked with * are reported as per statement of facts and/or information given by the ship or installation without any responsibility on our part for their accuracy.

Remarks: _____ Signatures: _____

Company Name of Superintendent: _____ Vessel's Representative: _____

Authorised Signatory: ***** (Surveyor) Master Chief Officer

LETTERHEAD/LOGO

Certificate No *****

Date *****

TYPICAL

CLEANLINESS OF HOLDS CERTIFICATE - OILSEEDS

Cleanliness of Holds Certificate

Bill of Lading No: *****
 Bill of Lading Date: *****
 Load Port: *****
 Destination: *****
 Quantity Loaded: ***** metric tonnes

WE HEREWITH CERTIFY

that we, ***** *Note 1*
 did attend on: *****
 on board of the vessel: *****
 lying at: ***** alongside supplier's installation

for the purpose of visually inspecting
 vessel's holds stated below for the
 loading of a parcel of: ***** oilseed in bulk

WE HAVE TO REPORT THAT

The material in question was to be
 loaded into the following vessel's holds: Nos *****

We confirm that, prior to commencement of loading, the accessible parts of the vessel's holds and hatches have been visually inspected and found, in these respects, to be free from infestation, clean, dry and suitable to carry ***** oilseeds.

Inspection completed on: *****
 At: ***** hours
 Authorised Signatory: *****

Note 2

Notes

1. Name of superintending company.
2. FOSFA Member Superintendent's full name and address details.

1 Name and address of exporter	2 PHYTOSANITARY CERTIFICATE NO:	
3 Declared name and address of consignee	4 Plant Protection Organisation of	
	to Plant Protection Organisation(s) of	
	5 Place of origin	
6 Declared means of conveyance	MINISTRY OF THE ISSUING GOVERNMENT	
7 Declared point of entry		
8 Distinguishing marks: number and description: name of produce botanical name of plants		9 Quantity declared
T Y P I C A L		
10 This is to certify that the plants or plant products described above - have been inspected according to appropriate procedures, and - are considered to be free from quarantine pests, and practically free from other injurious pests, and that they - are considered to conform with the current phytosanitary regulations of the importing country		
11 Additional declaration		
DISINFESTATION AND/OR DISINFECTION TREATMENT		Place of issue: Date: Name and signature of authorised officer Stamp of Organisation
12 Treatment		
13 Chemical (active ingredient)	14 Duration and temperature	
15 Concentration	16 Date	
17 Additional information		

INFORMATIVE ANNEX - SHIPMENT OF OILSEEDS - DAMAGE AND CONTAMINATION

1. SHIPMENT OF OILSEEDS

A variety of ocean-going ships are used for transporting oilseeds ranging from large bulk carriers, general cargo freighters, twin-deck cargo vessels, container vessels, coasters and sea-going barges. Oilseeds used for the extraction of oil are shipped in bulk or bags and, in some cases, in containers in bags. Internationally, oilseeds may also be transported on roads, railways and inland waterways.

Small changes in moisture content, dependent on the condition of the atmosphere, will not normally cause damage to oilseeds. However, if seeds are stored in a confined space, the lack of ventilation may lead to heating and sweating and evaporation may be excessive in parts of the seed, with condensation in other parts, leading to mould growth. This will lead to rapid increase in the Free Fatty Acid (FFA) content of the oil.

In the early stages, seeds stick together and form lumps, which break up easily unless the damage has become severe, when a bag of seeds may become a solid block. This type of loss may be partly attributable to the nature of the seed itself, i.e. quality (green) or to unfavourable weather conditions at the time of the harvest or to insufficient drying. The analysis on out-turn of both sound and damaged seeds should be checked as a guide to an assessment of allowance. Damage may also take the form of heating or bacteria activity causing hot spots, fermentation and, in some cases, loss in weight. Heating in storage will lead to mould growth and, in some cases where the temperature is high, scorching of the seed will be obvious.

Insect attack is more common with groundnuts than with palm kernels and may be recognised in the case of nuts in shell by the entry holes and, in the kernels, by numerous holes and the presence of larvae. Insect damage, as well as heating, results in increased fatty acid content. With insect damage, an intense attack will be denoted by the presence of a quantity of fine meal associated with the kernels. Normally there is no danger of loss of colour in groundnuts and palm kernels during transit.

2. DAMAGE AND CONTAMINATION

The causes of damage to oilseed cargoes can be divided into five main areas of concern -

Water damage from either sea or fresh water ingress into the ship, as well as water falling onto the cargo as snow or rain.

Major hold contamination from ships bunkers and bilges and previous cargoes in the hold (metal concentrates, chemicals, phosphate rock and coal).

Large admixture in the form of a variety of large debris consisting of stones, pieces of glass, concrete or other pieces of wreckage such as plastic, metals or wood.

Admixture in the form of small foreign materials like foreign seeds straw, traces of earth, small stones, sand, grains and excrements.

Infestation of the cargo from any number of a variety of pests (alive or dead) which are either eating the seeds or which are themselves poisonous or producing poisonous materials.

3. DAMAGE - INDIVIDUAL OILSEED VARIETIES

This annex contains information from a variety of information sources. It is designed to be of assistance to those FOSFA accredited Member Superintendents who are more aware of some of the common causes of damage in cargoes of oilseeds. It is also designed to assist Principals to FOSFA oilseed contracts to understand and interpret the reports and returns sent to them by FOSFA accredited Member Superintendents. The paragraphs below are commodity specific.

The paragraphs below will assist FOSFA accredited Member Superintendents to observe all aspects of loading or discharge of oilseeds cargoes and to report in precise detail to their Principal on the supervision tasks that they are undertaking in accordance with the contract.

4. INTERNATIONAL MARITIME DANGEROUS GOODS (IMDG) CODE

Reference to the IMDG Code, issued by the International Maritime Organisation (IMO), will provide the necessary information. The Code - which also forms the basis for legislation and recommendations for the transport of dangerous goods by road, rail and air - details nine classes with sub-divisions.

5. CASTORSEED

Castorseed is classed IMDG - Class 9 - Miscellaneous. It is normally shipped in bags, they must not be stored or stowed on vessels near or with foodstuffs or other edible commodities due to the poisonous nature of the castorseeds. The husk, when broken or split may become separated into tiny splinters which, if ingested, causes internal damage in humans and animals. Heating cannot usually be detected by external examination, but can be ascertained by internal discolouration.

6. COPRA

Copra is classed IMDG - Class 4.2 - Spontaneously Combustible. The IMDG Code states that copra shall not be shipped with a moisture content exceeding 6%. Copra is the dried kernel of the coconut, having a high oil content - sometimes as much as 66%. It is shipped bagged or, predominantly, in bulk. Three types are shipped; sun-dried, hot-air dried and smoke-dried. Weight loss may be significant, usually between 3-7% - in some cases reaching 10%. Copra will produce mould in damp conditions, becoming blackened and smelly. It is recommended that when shipping copra in containers, a mechanically vented container should be used and all bulk holds should be ventilated throughout the voyage. If a heavy green mould is present, accompanied by a heavy loss in weight, then in most cases it may be assumed that the copra was shipped in an unduly wet condition. If the green mould is present without major loss in weight, then it is possible that the copra has been in contact with water. This is not, however, a certain indication because if dry copra has been stored for a long time prior to shipment, then the same condition may arise. Copra, whether in bulk or bagged, requires the best possible ventilation to dispel moisture and gases. There is a risk of copra being damaged by even the smallest admixture of sulphur and it should not, therefore, be loaded with or immediately following a cargo of crude or fine sulphur.

Pests, Infestation and Fumigation - The principle pest is the Copra Beetle (*Necrobia rufipes* [Degeer]) which is a small black or electric blue beetle about 5 mm in length, which should not be a problem to receivers, except when the vessel has left the origin port without fumigation having been completed and arrives at final destination in a country with a prevailing warm temperature when the beetles may then emerge from the cargo. In the worst case, the beetles can fly out of an opened hold and into the port area. The presence of vermin or snakes should be notified by the superintendent to his Principals.

Insect Damage - Superintendents will be able to identify holes that have been bored by insects. These should be reported.

Admixture - It is possible that a superintendent may come across a wide variety of large and unwanted admixture from origin, including occasional large pieces of wood, jute sacking, binding twine, bailing wire, bricks and large stones (used as make-weight in copra sacks), household rubbish and discarded plastic containers.

7. COTTONSEED

Cottonseed is shipped in bulk or in bags and is generally classified as "white" or "black". The white variety has the woolly lint adhering to the seed, while the black has practically no lint adhering to it and the black and brown husk of the seed itself is visible. Cottonseed is liable to heat from inherent vice and the extent of internal damage is found by crushing the seed and estimating the extent of the damage by the discolouration of the seed. The lint on the white variety is liable to absorb moisture, thereby creating heat resulting in decomposition. Cottonseed is liable to spontaneous combustion, especially if loaded during wet or damp weather. The average moisture content for Tanzanian cottonseed is 8.9% and for Chinese it is 11.5%. It is anticipated that during a standard marine voyage up to 2.5% moisture can be lost.

8. SESAMESEED/GINGELLYSEED/BENNESEED

Sesameseed is generally shipped in bags in containers. The superintendent at loading is required to be able to observe the top of the cargo stack. In general, the bags will be piled in a warehouse. The superintendent should look on the floor around the bags for signs of vermin droppings, eaten bags or urine. He should record if there are any sealed vermin traps in the warehouse where the goods are stored prior to loading. Two or three days before loading, he should check again on the condition of the seeds/cargo.

Water Damage - Rain damaged seeds can be recognised because the outer skin is ribbled and not complete. High moisture can lead to mould and eventual destruction of the seed.

Heat Damage - The colour of the seeds will turn out to be darker than normal. The number of black seeds is not necessarily because the parcel has been affected by heat. In sesameseed, there are some black seeds that exist naturally. However, heat damage will burn the seeds and will strengthen their taste. Processors use heat to roast sesameseeds and the easiest change to control is the taste. Roasted sesameseed has a strong, pleasant, nutty taste.

Pests - In general, parcels of sesameseed are loaded correctly in clean containers that are insect and rodent free. The clearest signs of rodent presence are corners of bags eaten by mice, urine stains on the outside of the bags, mice droppings between the bags and mice droppings or live weevils in the seeds themselves.

Admixture - Examples of admixture are sticks, stones, weed seeds, sand, soil, glass, dead or living weevils, wood, metal pieces, other seeds (e.g. pumpkin seeds) and rodent droppings. The trade considers admixture to be anything that is not the specified seed. Some receivers take samples of each container and each sample is analysed, on 100 grams, to check the admixture to a degree of 0.01% exactness. Some traders manually remove all admixture from 100 grams and weigh it.

Tolerance for Black Coloured Seed - Some traders specify a tolerance for black coloured seed in their contract. In general, this varies from 1-10%.

9. SHEANUTS

This is the nut of a West African tree possessing considerable oil content; the oil being extracted for the manufacture of bakery and chocolate fats. It is mainly shipped in bags.

Sheanuts have a tendency to dry out and exude oil during storage and shipment. They are not well suited to storage in silos. Deterioration of nuts is faster in a moist and hot climate, whereas they store well under cold and drier conditions. In moist conditions, nuts should preferably be stored in a traditional warehouse with some ventilation to remove excess moisture as it evaporates in order to avoid condensation under-ceiling and, subsequently, dripping onto the top layer of the nuts.

Water Damage - Some sheanut traders say that, traditionally, a water content above 10% will give them cause for concern. During transportation, there is nearly always some condensation of moisture in certain areas of the cargo, resulting in mouldiness and, in extreme cases, a thorough soaking of the nuts. Over a longer period, this can make the nuts relatively "spongy" and, thus, unfit for crushing and certainly difficult to store without prior drying. Since the nuts originate in areas with high temperatures and humidity and are typically processed in colder and often drier environments, transportation will cause condensation. Hence, ventilation leading to absorption of excess moisture during shipping if possible is highly recommended. The problem peaks during the rainy season (August to October).

Mould Damage - The superintendent should report any mould damage that is present in the cargo and, in particular, the extent of the mould coverage.

Admixture and Contamination from Oils - External sources of admixture in sheanuts are typically dirt, dust and stones from origin. Superintendents should be careful to check storage facilities and look out for any mixture with cottonseed expellers and palm kernel expellers, since these are frequently shipped from the same areas as sheanuts and could contain aflatoxin. Furthermore, the oils derived from cottonseed and palm kernel are detrimental to the shea butter and the oil products should therefore not be present when milling the sheanuts. The principle risk in bulk shipment is when tween-deck hatch covers are not completely tight and oil penetrates into the hold containing the sheanuts.

10. RAPSEED/CANOLA - DAMAGED KERNELS

Rapeseed is classed IMDG - Class 4.2 - Spontaneously Combustible. Damaged kernels include rapeseed and pieces of rapeseed that are heat damaged, sprout damaged, mould damaged, distinctly green damaged, frost damaged, rim damaged or otherwise materially damaged.

Basis of Determination - Determine the amount of damaged kernels on a representative portion cut from the work sample after the removal of dockage and conspicuous admixture. Use the portion which was used for picking dockage and conspicuous admixture. Note this portion must be re-weighed. Damage must be distinct. In general, a kernel of rapeseed is considered damaged when the damage is distinctly apparent and of such character as to be recognised as damaged for commercial purposes. Insect bored kernels are not considered damaged.

Distinctly Green Kernels - Rapeseed and pieces of rapeseed which, after being crushed, exhibit a distinctly green colour.

Heat Damaged Kernels - Rapeseed and pieces of rapeseed which, after being crushed, exhibit discolouration and damage by heat. Some rapeseed may be so badly overheated during commercial drying that it is burnt and some seeds may be black and there may be a distinct smell of burnt seed.

11. SOYABEANS - FEDERAL GRAIN INSPECTION SERVICE CLASSIFICATION

The United States Department of Agriculture Federal Grain Inspection Service (FGIS) publishes a Grain Inspection Handbook in which it refers to visual grading aid and interpretive line slides and prints. These can be used to assist in making subjective grade determinations on general appearance. The Seedburo Equipment Company is responsible for the production and distribution of Interpretive line slides, slide viewers and other equipment. All correspondence and orders concerning this equipment should be made to the Seedburo Equipment Company, 1022 W Jackson Boulevard, Chicago, IL 60607, USA. Tel 00-312-738-3700. The FGIS quotes two classes of soyabeans -

Yellow Soyabeans - These have yellow or green seed coats and which, in cross-section, are yellow or have a yellow tinge and may include not more than 10.0% of soyabeans of other colours.

Mixed Soyabeans - These are soyabeans that do not meet the requirements of the classification of yellow soyabeans.

Basis of Determination - Determine the class by the colour characteristics of the kernels on a portion of 125 grams after the removal of foreign matter.

Soyabeans of Other Colours - These have green, black, brown or bi-coloured seed coats. Soyabeans that have green seed coats will also be green in cross-section. Bi-coloured soyabeans will have seed coats of two colours, one of which is brown or black and the brown, with the black colour covering over 50% of the seed coats. The hilum of a soyabean is not considered part of the seed coat for this determination. (Reference - Interpretative Line Slide No SB-12.0).

Soyabeans - Types of Damage - If soyabeans are shipped in a damp condition they may heat, sweat and ferment. In general, a soyabean is considered damaged for inspection and grading purposes only when the damage is distinctly apparent and of such character as to be damaged for commercial purposes.

Badly Ground/Weather Damaged Kernels - Soyabeans and pieces of soyabeans in which the seed coats are discoloured by ground or weather damage. The damage may be on one or both sides. (Reference: Interpretive Line slide No. SB-1.0 and SB-1.1).

Frost Damaged Kernels (Green or Waxy) - Soyabeans and pieces of soyabeans which are discoloured green in cross-section or which have a glassy or wax-like appearance. (Reference - Interpretive Line Slides No SB-3.0 and SB-3.2).

Heat Damaged Kernels - Soyabeans and pieces of soyabeans which are materially discoloured and damaged by heat. Often kernels need to be cross-sectioned to determine the extent of damage. Do not cross-section splits and pieces of soyabeans. (Reference - Interpretive Line Slide No SB-5.0).

Immature Kernels (Wafers) - Cross-section soybeans and pieces of soyabeans that are immature and have a thin, flat, wrinkled or wafer-like appearance to determine if there is "meat" in the kernel. Wafered kernels with no "meat" are considered damaged. (Reference - Interpretive Line Slide No SB-6.0).

Mould Damaged Kernels - Soyabeans and pieces of soyabeans which contain mould. (Reference - Interpretive Line Slide Nos SB-8.0 and SB-8.1).

Invaded by Mould - Soyabeans that are discoloured, distorted, misshapen, elongated or abnormal may have splits, cracks or fissures in the seed coat and contain a white to grey mouldy growth. (Reference - Interpretive Line slide Nos SB-8.0-A).

Surface Mould Growth - Soyabeans with little or no apparent deterioration and having a milky white or greyish crusty growth caused by downy mildew. (Reference - Interpretive Line slide SB-8.0-B).

Mould Damage (Pink) - Soyabeans and pieces of soyabeans with a pink discolouration caused by fungal activity. (Reference - Interpretive Line slide No SB-8.1).

Sprout Damaged Kernels - Soyabeans and pieces of soyabeans which are sprouting with the sprout protruding. (Reference - Interpretive Line slide No SB -9.0).

Infested Soyabeans - The presence of any live weevil or other live insects injurious to stored grain indicates the probability of infestation and means that the soyabeans must be carefully examined to determine if they are infested. Live weevils include rice weevils (*Sitophilus zeamais motschulsky* [greater], *Sitophilus oryzae* L. [lesser]), granary weevils (*Sitophilus granarius* L.), cowpea weevils (*Callosobruchus* SPP), maize weevils (*Sitophilus zeamais motschulsky*) and lesser grain borers (Larva of *Rhyzopertha dominica* [Fabricius]). Other live insects injurious to stored grain include grain beetles, grain moths and larvae.

12. SUNFLOWERSEEDS

Types of sunflowerseed vary considerably. Varieties are mainly black, white or black/white striped. It is shipped in bags or in bulk. If it is stored in a confined space with a lack of ventilation, this may lead to heating and sweating which may, in turn, lead to localised mould growth. There is a risk of spontaneous combustion if the sunflowerseeds are shipped wet. Sunflowerseed will often contain a high percentage of fine dust or sand.

Infestation - Infested sunflowerseed is that which is infested with live weevils or other live insects injurious to stored oilseeds or grain. Live weevils include rice weevils, cowpea weevils and lesser grain borers. Other live insects include grain beetles, sunflower moths, banded sunflower moths, Indian meal moths, grain moths and larvae. Larvae of the red or grey sunflowerseed weevil (*Smicronyz* spp) are small, white, legless grubs approximately 1/8 inch in size that wander among sunflowerseeds. When disturbed, these larvae curl into a ball and remain motionless for minutes. They chew out from inside the sunflowerseed and cannot re-infest the seed in storage.

13. LINSEED/FLAXSEED - TYPES OF DAMAGE

Damage is defined as kernels and pieces of linseed that are badly ground damaged, badly weather damaged, diseased, frost damaged, germ damaged, heat damaged, insect bored, mould damaged, sprout damaged or otherwise materially damaged.

Types of Linseed/Flaxseed Damage - Damaged linseed/flaxseed is usually characterised by a distinct discolouration, such as white, dark brown or black discolourations caused by disease or by a mouldy, scabby or dead appearance. Very thin whitish, paper-like seeds of linseed, which can be referred to as "fly's wings" or "bee's wings" are considered as damaged.

Heat Damaged Linseed/Flaxseed - When heat damaged kernels are present, linseed gives off an odour similar to smoke. If evidence of a fire-burnt material is present in the lot or the sample, the smoke odour is considered a commercially objectionable foreign odour.

14. PALM KERNELS

Palm kernels are mostly shipped in bags. Before shipment, they should be dried to acceptable normal moisture levels. They are used for the extraction of oil and the manufacture of cattle feed. According to the degree of freshness, palm kernels exude a variable percentage of oil, which can be noted by the dark colour and greasy state of the sacks.

Stowage near boilers or in a damp holds is liable to provoke mould, usually a white film. If soaked for any length of time, palm kernels will swell and soften. In particular, a characteristic sour smell indicates damage. Palm kernels are liable to heat and sweat. Care should be taken to ensure that the kernels are not infested with any pests, in particular, a giant 3 inch long flying black Palm Weevil. This pest is attracted to and feeds upon wounded, dying or young trees. It likes to feed/colonise in a tree's crown. The eggs hatch into larvae that eat through the palm tree and, within 30 days, reach the size of a small sausage.

The information contained in this Informative Annex is collated from various sources for the benefit of the reader and is intended for guidance only.



FOSFA
INTERNATIONAL

GROUNDNUTS (PART 3)

1. GLOSSARY OF TERMS

This glossary of terms is for use in the International Trade in Groundnuts.

Broken - More than one fourth of the groundnut kernel is broken off.

Defects - Comprises the following -

Dirt - When the surface of the kernel is distinctly dirty and its appearance is materially affected.

Flesh Discolouration - The flesh colour is darker than a light yellow colour or consists of more than a slight yellow pitting of the flesh.

Infestation - Presence of live or dead insects.

Mould - An attack by micro-organisms if the moisture content rises above a certain maximum. The parcel is expected to be substantially free from mould.

Skin Discolouration - A colour which is dark brown, dark grey, dark blue or black and covers more than one fourth of the surface.

Sprouting - A sprout extending more than 3mm from the tip of the kernel.

Foreign Material - Pieces or loose particles of any substance other than groundnut kernels or skins or, when in hull (shell), pieces of shell and stalk.

General Defects - The groundnut kernel is affected by one or more of either rancidity, decay, mould, insect or worm cuts, web or frass, freezing injury (causing hard translucent or discoloured flesh). The kernel might also be unshelled or dirty where the surface of the kernel is heavily smeared or coated with dirt, seriously affecting its appearance.

Identity Preservation - Bagged lots of groundnuts should be accumulated and stored in such a way as to maintain identity by ship, mark and lot number.

Portion - Part, or parts, of a groundnut kernel other than a whole.

Split - Separated half of a groundnut kernel.

Types of Peanuts in the USA - There are mainly three types of peanuts grown in the USA, namely, Virginias, Runners and Spanish. There are also Valencia peanuts.

Virginias - Often called "cocktail" nuts and are considered large kernels.

Runners - Medium sized kernels.

Spanish - Small sized kernels.

Valencia - Grown less frequently in the USA and are identified by three or four small kernels in a long shell.

Unshelled - Groundnut kernel enclosed in part, or all, of the hull (shell).

Whole - Groundnuts which are not split or broken.

2. FUNCTIONS OF SUPERINTENDENTS

2.1 GENERAL

To act on his Principal's instructions in a professional manner, performing in person those operations required of him, observing conduct of operations by others and protecting the interests of his Principal. The superintendent should report any departures from normal and/or specified practice to his Principal.

2.2 CONTRACT PARTIES

Within FOSFA contracts, a superintendent may be appointed by either Buyer, Seller or both.

2.3 SCOPE OF INTERVENTION

Must be fully acquainted with the relevant FOSFA contract terms, remaining within these, not assuming responsibilities which are not covered by his instructions.

2.4 AUTHORISATION

Following upon 2.2 and 2.3 above, the other contractual party and other interested parties must be advised in detail of the nominations of, and the requirements delegated to, the superintendent.

2.5 RESPONSIBILITY

The Principal must accept the immediate and consequential effects and costs to all involved parties of the superintendent's intervention on his behalf.

2.6 MAIN OPERATIONS

2.6.1 Attending the loading or discharging of ships, containers, barges, craft, lorries, trailers or rail wagons (including the reporting of facilities available), inspection of the containers and vessel holds and for cleanliness, measurement of quantities, sampling for the presence of moisture, impurities, weights and quality (as specified in the contract) and the production of Certificates of Weight, Count and Fumigation, if required.

2.6.2 Issue survey reports as called for under the relevant contract.

3. OPERATING PRACTICES

3.1 CONDITIONS

As considerable variation of conditions exist under which the superintendent may have to undertake his work, the following practices can only be applied where conditions permit.

3.2 GENERAL PRACTICE

The Code effectively constitutes recommendations for the performance of operations which are basically similar for loading and discharging and may generally be applied to storage, transportation and handling equipment without significant change for the type and size of that equipment.

3.3 PARTICULAR PRACTICE

Included within Part Three of this Code is a Check List (Annex I) for typical loading and discharging operations of groundnuts to assist the superintendent in following the sequence of the particular operation.

4. SHORE PRACTICES AT LOADING AND DISCHARGE

4.1 CONTAINER SHIPMENTS

The superintendent must be prepared to report upon the quantity, size and general description of the containers in use, including the container serial number. He should ascertain the total number of containers, description and marking to assist with container identification.

4.2 CONTAINERS/VESSEL HOLDS

The container or vessel holds must be serviceable and free from any taint, smell or contamination from any previous cargo. The inside of the container hold must be dry. The superintendent should inspect the containers or vessel holds to ensure that it is fit for use for the shipment of the cargo concerned. After inspection of the containers and/or vessel holds for their condition, the superintendent may reject the container or ship's hold and/or inform his Principal.

4.3 GENERAL PURPOSE CONTAINERS - CHARACTERISTICS

As the name suggests, this closed container is suitable for the carriage of all types of general cargo and, with suitable temporary modification, for the carriage of bulk cargoes, both solid and liquid. The containers are basically a steel framework with steel cladding. In all cases, the floors are either hardwood timber planked or plywood sheeted. Access for loading and unloading is through full width doors positioned at the rear of the container. Cargo securing/lashing points are located at floor level at the base of the side walls (generally 5 per side in 20' and 9 per side in 40' containers, all with a safe working load of 2032 kg each).

4.4 FREIGHT CONTAINERS

Freight containers for carriage of groundnuts and other oilseeds in international trade will normally be those complying with ISO requirements. All standard containers will be 8ft (2.4m) width, one of three heights 8ft (2.4m), 8ft 6in (2.6m), 9ft 6in (2.9m) and of lengths 10ft (3m), 20ft (6m), 30ft (9m) or 40ft (12m). There are two main types designated as ISO containers -

4.4.1 General Cargo Containers (ISO 1496-1)

Mostly totally enclosed but include ventilated and open-top for specific purposes. All have at least one of their end walls equipped with full-width doors. Specifically for carriage of groundnuts and other oilseeds, the basic closed container, the ventilated container and the open-top container fitted with waterproof cover, are normally used to carry bagged cargo although the open-top container may be used for carriage of dry bulk cargo in the same way as a dry bulk container.

4.4.2 Non-Pressurised Dry Bulk Containers (ISO 1496-4)

Like the general cargo containers, these are closed but also include ventilated types for specific purposes. They are intended for carriage of free-flowing dry bulk products.

All have one or more openings for loading to permit proper distribution of the dry product loaded into the container all have one or more openings for discharging, allowing for complete discharge by natural gravity with particular regard for area to achieve total discharge by tilting the container. Additionally, they may be compartmented internally and have fixings to accommodate linerbags. There are two types of dry bulk containers -

Box Type - Generally intended to discharge by tipping and in addition to the loading and discharging openings, has a full width door opening at least at one end which therefore makes it possible to use as a general cargo container.

Hopper Type - For horizontal discharge but having no full width door opening thus not permitting its use as a general cargo container. In addition, hopper types have adequate manholes to give access for cleaning and inspection.

4.4.3 As noted above, within the two basic types, general cargo and dry bulk, there can be some cross over of use whereby general cargo containers may be used for non-packed dry bulk products and dry bulk containers with full width doors may be used for packed goods.

4.5 TARE - PAYLOAD AND GROSS WEIGHTS

The tare weights of containers vary, therefore no absolute figure is quoted for payload. However, very careful consideration must be given to the maximum weight limits acceptable in the country of origin and destination.

20ft x 8ft x 8ft 6in Units 6.1m x 2.4m x 2.6m

<i>Average interior dimensions</i>			<i>Door dimensions</i>		<i>Cubic capacity average</i>
L1	B1	H1	B2	H2	
5890mm	2345mm	2400mm	2335mm	2290mm	33.3m ³

Tare weights vary between 1800kg and 2500kg.

40ft x 8ft x 8ft 6in Units 12.2m x 2.4m x 2.6m

<i>Average interior dimensions</i>			<i>Door dimensions</i>		<i>Cubic capacity average</i>
L1	B1	H1	B2	H2	
12015mm	2345mm	2362mm	2335mm	2260mm	66.9m ³

Tare weights vary between 3700kg and 4380kg.

4.6 VENTILATED CONTAINERS - CHARACTERISTICS

Primarily designed for the coffee trade, these containers are of steel construction and, to all intents and purposes, are the same as the general purpose container, except for the inclusion of full length ventilation galleries sited along the top and bottom side rails, allowing the passive ventilation of the cargo. The ventilation arrangement is such that the ingress of water is prevented. (Note - the internal width is restricted slightly at the top and bottom of the container).

4.7 DAMAGE TO CONTAINERS

Freight containers can sustain damage in a number of ways. The Institute of International Container Lessors (IICL) and the International Chamber of Shipping (ICS) have issued a guide (IICL-5) which includes a guide for container equipment inspection, container design features, inspection procedures, documentation requirements, non-conforming repairs, damage and wear and ISO dimensions and tolerances. Colour photographs of damage, diagrams and a glossary are also included.

The subject of container damage is wide, but damage basically falls into the following groups-

- physical defect in container structure.
- staining or damage to floor.
- general taint within container.

Any of the above would prevent acceptance of an empty container for loading cargo. (Note - copies of IICL-5 can be obtained from IICL, Box 605, Bedford, NY 10506, USA. Fax No: 914-234-3641).

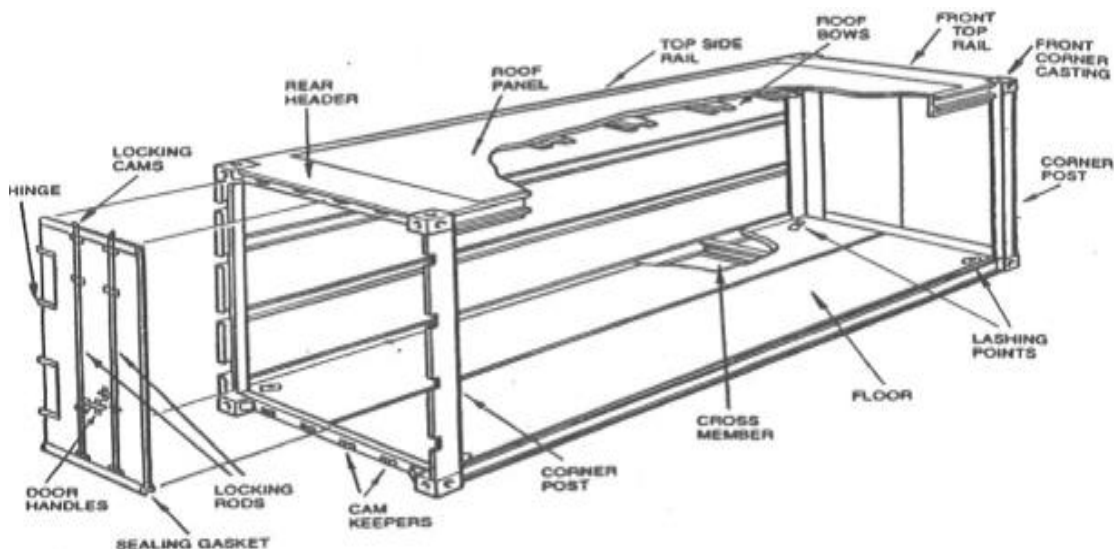

4.8 VESSEL HOLDS

Where groundnuts are shipped in sacks stowed in holds, the superintendent should inspect the hold itself to ensure it is totally clean from the previous cargo and should also report on the serviceability of the hold in question. Inspection of the vessel's holds may require a statement from the Master/Chief Officer.

4.9 WEATHER

The superintendent will report on the condition of the weather at the time of loading/discharge and record in his log if high winds, rain, snow, frost, hail or humidity were present at the time and the start and finish of such events.

4.10 WEIGHBRIDGE OPERATION

The superintendent will, wherever possible, ensure that the container/weighbridge produces an authorised checkweight slip and he will also, wherever possible, satisfy himself that the weighbridge has been properly inspected and officially certified for use.

4.11 CARGO CHECKWEIGHT BASED ON A RANDOM WEIGHT

The superintendent will report upon the weight of the individual bags in the containers by random sampling. He will check the total weight of the loaded container. The superintendent will arrive at the checkweight of the quantity of bags, based on 5% of bags by random weighing, in accordance with up-to-date approved statistical practice.

Checkweighing of a relatively small percentage of bags selected at random is rather meaningless unless the weight of all the bags is equalised. This is not always the case everywhere. If the weight of all the bags is not equalised then the weighing should be carried out on a 100% basis.

4.12 CERTIFICATE OF QUALITY AND CONDITION

The superintendent will certify whether the groundnuts are the contractual type and grade and are free from mould, infestation and obvious presence of rodents (holes in the sacks). He will visually report on the colour, damage and the presence of foreign material (see Appendix II).

5. FUMIGATION

5.1 If fumigation is required and, if agreed with the Principal, the superintendent will produce a Certificate of Fumigation. The Certificate may be the document issued by the fumigation contractor. The Certificate will show that fumigation has taken place and in particular it will include -

Numbers of the containers loaded onto vessel.

Date that groundnuts were stuffed into the containers.

Date fumigation carried out and, if necessary, actual position of fumigant within container.

Quantity of chemical being used and, if specified, a toxicological profile of the chemical/fumigant.

Dosage of fumigant in terms of size of container, e.g. 4 grammes per cubic metre.

5.2 REPORTING AFTER FUMIGATION

The superintendent or fumigation contractor may have to report his findings to his Principal after fumigation has taken place. This may involve reporting on how fumigation has been conducted and the residue levels.

In some cases, the fumigation of goods stowed in containers is carried out shortly before the loading of the containers on board a vessel takes place. By the time the containers are on board the vessel the fumigation process may not necessarily be completed (for example, when fumigation is carried out with aluminium phosphide, the exposure time may stretch over three to five days). When containers are loaded on board a vessel before this period of time has expired, it is no longer possible to open them in order to draw samples on which the level of fumigant residues could be measured at the port of loading.

5.3 CERTIFICATE OF FUMIGATION

An example of a Certificate of Fumigation is shown at Appendix V.

5.4 Attached at Annex III is an informative guide on fumigation.

6. SAMPLING

6.1 GENERAL

Sampling should be in accordance with the contractual methods as laid down in the FOSFA Technical Manual. Sampling requirements and points of sampling are given in FOSFA contracts. The number of contract samples to be drawn for analysis and arbitration are specified in the relevant contract or otherwise agreed between Buyer and Seller. All contract samples must be sealed.

6.2 SAMPLE DEFINITIONS

Consignment - The quantity of oilseed despatched or received at one time and covered by a particular contract or shipping document. It may be composed of one or more lots or parts of a lot.

Lot - A stated quantity of the consignment, which in itself is presumed to be of uniform characteristics, and which will allow the quality to be assessed.

Increment - A small quantity of oilseeds taken at one time from a single position from a stationary lot, or taken throughout the moving lot. A series of increments is taken from different parts of the stationary lot, or throughout the moving lot, so that when they are bulked, they are representative of the lot.

Bulk Sample - The quantity of oilseeds obtained by combining and blending the increments taken from a stationary lot or throughout a moving lot.

Laboratory Sample - Representative quantity of oilseeds obtained by division of the bulk sample and intended for analysis or other examination.

6.3 SAMPLING EQUIPMENT

The superintendent will use a variety of internationally accepted sampling equipment.

6.4 ANALYSIS METHODS - GROUNDNUTS

The FOSFA Standard Contractual Methods of Sampling for Groundnuts including bulk sampling, sample reduction, sample preparation, packaging and labelling, are to be found in the FOSFA Technical Manual in the Oilseeds Section.

If instructed by the Principal, superintendent will submit samples to an approved FOSFA laboratory for any analysis including aflatoxin. During the loading of the sacks into containers, one sample will be drawn from each container from a given percentage of the bags. The laboratory to quote results on an authorised Certificate of Analysis showing container number, result of tests and date on which analysis was carried out. Superintendent to include certificate with contractual documents if agreed with Principal.

CHECK LIST FOR OPERATIONS - GROUNDNUTS

CHECK LIST AT LOADING

Typical operation of loading water-borne vessels from shore sources.

1. BEFORE LOADING

1.1 BEFORE SHIP'S ARRIVAL OR AVAILABILITY CONTAINERS

Locate goods and carry out a superficial inspection of the cargo.

1.2 UPON SHIP'S ARRIVAL OR AVAILABILITY CONTAINERS

Verify nature of previous cargo(es).

Check cleanliness of holds or containers and their suitability for fumigation purposes.

Check cleanliness of vehicles used during loading operations.

Request collection/elimination of residues of previous cargo(es), if any present.

Carry out final inspection of holds or containers and vehicles.

2. DURING LOADING

2.1 SUPERVISION OF WEIGHING

Check the weighing installation/scales.

Exercise a regular control of the weighing operations.

Request recovery of all loose material/spillages in sound condition in warehouse, on quay and on ship's deck.

If weighing is via weighbridge, check tare of vehicles. Check movement of vehicles during operation.

Check cleanliness of weighbridges.

2.2 SUPERVISION OF LOADING

Check that all goods are loaded and check that all vehicles (including lighters) are empty.

Check handling equipment for possible inadequacies.

Record and report on weather conditions.

Ascertain where possible and report any loss/damage to cargo during loading operations.

Ascertain where possible and report who is responsible for loss/damage and lodge letters of reserves.

2.3 STOWAGE CONTROL

Check and report where cargo is stowed for each commodity, consignment, lot, shipper, etc.

Check and report on separations (if any).

2.4 QUALITY INSPECTION

Sampling to be effected according to sampling rules or client's instructions.

Compose required number of samples and sealing of samples.

Inspect goods for presence of live weevils, insects, etc, and report.

3. AFTER LOADING

Attend and report on the fumigation operations (if any).

CHECK LIST AT DISCHARGE

1. BEFORE DISCHARGE

1.1 BEFORE SHIP'S ARRIVAL

Contact parties concerned (Buyers, receivers, ship's agent).
Study loading details and compare with instructions.

1.2 UPON SHIP'S ARRIVAL

Carry out an inspection of holds or containers condition, stowage and cargo condition.
Check cleanliness of discharge equipment.
Attend and report on fumigation (if any).

2. DURING DISCHARGE

2.1 SUPERVISION OF WEIGHING

Check the weighing installations/scales.
Exercise a regular control of the weighing operations.
If weighing is via weighbridge, check tare of vehicles.
Check movement of vehicles during operation.
Check cleanliness of weighbridge.
Check the correct delivery of consignment/lots.
Tally the bags.

2.2 SUPERVISION OF DISCHARGE

If there is damaged cargo, ascertain it and classify it separately.
Check that all loose merchandise and sweepings are weighed and delivered. Check that holds or containers are empty after discharge.
Record and report on the weather conditions.
Address letters of reserves to carriers and their agents in case of missing packages and/or damaged cargo.

INFORMATION TO BE GIVEN ON CERTIFICATES - GROUNDNUTS

STANDARD REQUIREMENTS

1. Superintendent's logo.
2. Name and address of superintendent.
3. Certificate number.
4. Date and place of issue.
5. Description of certificate (weight, quality).
6. Name of Principal.
7. Summary of Principal's instructions.
8. Description of consignment -
 - a. Transfer from other conveyance -
 - i. From.
 - ii. To.
 - b. Number of packages (or bulk).
 - c. Type/description of packages (if any).
 - d. Condition of stowage bags (if any).
 - e. Mark on packages (if any).
 - f. Declared weight.
 - g. Commodity (as declared).
 - h. FOSFA contract number (if known).
9. Findings (depending on mandate) such as -
 - a. Hold or container inspection.
 - b. Sampling.
 - c. Weighing.
 - d. Loading.
10. Date and place of intervention.
11. Signature.

VARIABLE REQUIREMENTS

1. Names of Buyers/Sellers.
2. Additional findings -
3. Cleanliness inspection of ship's holds and hatches (when groundnuts are not shipped in containers) -
 - a. Specify holds and hatches inspected.
 - b. Certify condition of holds.
 - c. Certify and report on excessive dust.
 - d. Certify and report on live infestation or mould.
 - e. Report on presence of water or the ingress of water.
 - f. Report on foreign matter (stones, metal, dirt).
 - g. Date, time and place of inspections.
4. Cleanliness inspection of containers (if any are used for shipment purposes) -
 - a. Specify quantity of containers used, their numbers and marks.
 - b. Certify condition of containers.
 - c. Certify and report on excessive dust.
 - d. Certify and report on live infestation or mould.
 - e. Report on presence of water/humidity.
 - f. Report on foreign matter (stones, metal, dirt).
 - g. Date, time and place of inspection.
5. Sampling -
 - a. Number of samples drawn and sealed.
 - b. Details of seals.
 - c. Distribution/disposal of samples.

6. Supervision of weighing -
 - a. Type and description of scales.
 - b. Weight (ascertained or calculated).
7. Other findings, such as -
 - a. Quality/condition of the groundnuts (analysis and by whom carried out).
 - b. Quality/condition of packages.
 - c. Method of loading (from warehouse, lorries, railway cars, lighters).
 - d. Details of co-mingling with other parcels (if any).
8. Reference to loss/damage during loading, abnormal weather conditions to which cargo has been exposed.
9. Timelog of loading operations.
10. Details of fumigation procedure (if any).

DISCHARGE REPORTS/CERTIFICATES

As far as applicable, use the same presentation in issuing discharge reports in which the following additional variable findings may be of particular interest to parties concerned, especially so in case of damage or abnormally high shortage.

1. Whether fumigation carried out before discharge.
2. Method of discharge.
3. Loss on discharge.
4. Details of sweepings carried out. Quantity of sweepings, damaged cargo and location/sampled separately.
5. Quantity of sweepings recovered/sampled separately (if any).
6. Quantities remaining on board (as estimated jointly with receivers'/carrier's representatives).
7. State of ship's/shore conveyors before and after completion of discharge (full/empty).
8. Details of disposal of damaged cargo, if known.
9. Condition of groundnuts.
10. Condition of packages.

Furthermore -

11. Prorata details (if any).
12. Reference to loss/damage in transit or discharge.
13. Reserves made by superintendent (or receiver).

APPENDICES - TYPICAL CERTIFICATES

Appendix I	Certificate of Weight.
Appendix II	Certificate of Quality and Condition.
Appendix III	Certificate of Physical Quality and Condition.
Appendix IV	Certificate of Cleanliness and Condition of Container.
Appendix V	Certificate of Fumigation - Containers.

LETTERHEAD/LOGO

Certificate No *****
Date *****

TYPICAL CERTIFICATE OF WEIGHT

In pursuance of an order received from shippers *****, requesting us to carry out the instructions summarised as under:

- Supervision of stuffing into containers.
- Control of weight.

OF A CONSIGNMENT DESIGNATED BY SHIPPERS AS:

***** bags with ***** kilos gross for net of ***** Groundnut Kernels, HPS, Runner ***** Count, ***** Crop, to be loaded onto vessel ***** , at the port of

*****. WE CERTIFY AS FOLLOWS:

Sampling Date: On ***** at warehouse of ***** plant, *****.

Stuffing Date: On ***** at warehouse of ***** plant, *****.

Supervision of Stuffing: We supervised all steps of stuffing into containers at above mentioned plant.

Weight: Was ascertained by weighing of cargo for each container in official weight bridge resulting:

LOT NO	BAGS	KILOS GROSS FOR NET	CONTAINER NO

Total Weight: ***** bags with ***** kilos gross for net.

Packing: New jute bags.

Declared Marks: *****

Our findings are valid at time and place of our intervention only.

Authorised Signatory: *****

LETTERHEAD/LOGO

Certificate No *****
Date *****

TYPICAL

CERTIFICATE OF QUALITY AND CONDITION

In pursuance of an order received from shippers ***** , requesting us to carry out the instructions summarised as under:

- Sampling for determination of quality, counting and

grading. OF A CONSIGNMENT DESIGNATED BY SHIPPERS AS:

***** bags with ***** kilos gross for net of ***** Groundnut Kernels, HPS, Runner ***** Count, ***** Crop, to be loaded onto vessel ***** , at the port of *****.

WE CERTIFY AS FOLLOWS:

Sampling Date: On ***** at warehouse of ***** plant, *****.

Stuffing Date: On ***** at warehouse of ***** plant, *****.

Sampling: On Principal's order, we followed sampling procedure laid down in EC Commission Directive 98/53/EC. During filling of bags we obtained, with automatic sampler, one incremental sample per every bag, which were proportionally mixed, quartering and well homogenised to yield the aggregate sample of about 1 kilo for physical analysis.

Analysis: On shippers order, one of these representative samples of each lot was delivered to a laboratory which is recognised as a Member Analyst by FOSFA International, for analysis purposes. The average samples per each container was proportionally mixed forming a representative composite sample, which was analysed to determine:

- a. Chemical Analysis:
Moisture *****
- b. Counting:
Determining kernels per ounce of ***** grams. See Table 1 below.
- c. Condition:
We determine organoleptical quality and condition as per ***** Regulation issued by ***** official state entity.

TABLE 1

LOT NO	COUNT	CONTAINER NO

Conclusions: The representative sample of the cargo corresponds to ***** Groundnut Kernels complying to grade * as per Official ***** Regulation for exportation of above mentioned goods; therefore we conclude that the goods were stuffed in apparently sound condition and according with FOSFA's Contract No ***** are warranted of good merchantable quality of their description. Inspected goods are of uniform colour, substantially free from visible mould, infestation and obvious presence of rodents.

Our findings are valid at time and place of our intervention only.

Authorised Signatory: *****

LETTERHEAD/LOGO

Certificate No *****
Date *****

TYPICAL CERTIFICATE OF PHYSICAL QUALITY AND CONDITION

In pursuance of an order received from Principals, requesting us to carry out the instructions summarised as under:

- Analysis according ***** rules and instructions received from suppliers.

OF A CONSIGNMENT DESIGNATED BY PRINCIPALS AS:

***** bags with ***** kilos gross for net of ***** Groundnut Kernels, HPS, Runner ***** Count, *****Crop, to be loaded onto vessel ***** , at the port of *****.

Shippers: *****
Customer: *****

WE CERTIFY AS FOLLOWS:

Sampling Date: On ***** at warehouse of ***** plant, located at *****.
Stuffing Date: On ***** at warehouse of ***** plant, located at *****.

Sampling: On Principal's order we followed sampling procedure laid down in EC Commission Directive 98/53/EC. During filling of bags we obtained with automatic sampler one incremental sample per every bag, which were proportionally mixed, quartering and well homogenised to yield the aggregate sample of 1 kilo for physical analysis.

Analysis: On Principal's order one of these representative samples of each lot was delivered to a laboratory in ***** , to determine general condition, quality and the following items:

TABLE'S REFERENCES

REFERENCES	LOT NO	CONTAINER NO	ANALYSIS REPORT
A			
B			
C			

Continued over the page ...

TABLE 1

PHYSICAL ANALYSIS	A	B	C
Count (Kernels per ounce 28.35 grams)			
Broken/Splits			
Other Type			
1. Minor Defects			
1.1. Raw Material			
Skin Discoloration			
Sprout			
Dirty			
1.2. Blanched Material			
Flesh Discoloration			
Subtotal			
2. Damaged Kernels			
2.1. Raw Material			
Heavy Dirt			
2.2. Blanched Material			
Rotten/Decay			
Mould			
Insect Damaged			
Freeze Damaged			
Subtotal			
TOTAL 1 + 2			
Flavour and Odour			
Foreign Matters per Bags (on two individual bags)			
PHYSICAL ANALYSIS ON BLANCHED PEANUTS			
Brown Spots after Drying			
CHEMICAL ANALYSIS			
Moisture			
FFA (Free Fatty Acids as Oleic)			

The representative sample of the cargo correspond to: "***** Groundnut Kernels". Therefore, we conclude that the goods were stuffed in apparently sound condition and according with FOSFA's Contract No ***** are warranted of good merchantable quality of their description. Inspected goods are of uniform colour, substantially free from visible mould, infestation and obvious presence of rodents.

Our findings are valid at time and place of our intervention only.

Authorised Signatory:*****

LETTERHEAD/LOGO

Certificate No *****
Date *****

TYPICAL CERTIFICATE OF CLEANLINESS AND CONDITION OF CONTAINER

In pursuance of an order received from shippers ***** , requesting us to carry out the instructions summarised as under:

- Inspection for cleanliness condition of containers.

OF A CONSIGNMENT DESIGNATED BY SHIPPERS AS:

***** bags with ***** kilos gross for net of "*****Groundnut Kernels, HPS, Runner ***** Count, *****Crop, to be loaded onto vessel ***** , at the port of ***** .

WE CERTIFY AS FOLLOWS:

Containers: Lot No *****
 Lot No *****

Sampling Date: On ***** at warehouse of ***** plant, ***** .

Stuffing Date: On ***** at warehouse of ***** plant, ***** .

Inspection Details: The above mentioned containers were visually inspected by us as far as it was possible/accessible for cleanliness only and found empty, clean, dry, free from foreign odour and contamination by previous cargo. In our opinion the container was found in good condition of cleanliness at time of our inspection and in this respect suitable for loading of edible peanuts.

Authorised Signatory: *****

LETTERHEAD/LOGO

Certificate No *****
Date *****

TYPICAL CERTIFICATE OF FUMIGATION - CONTAINERS

Pursuant to an order received from: *****
Requesting us to intervene as summarised: Fumigation
On a consignment designated as: ***** bags of groundnut
kernels Loaded on board: *****

As per the following Bill of Lading details:

Bill of lading nos: *****
Place and date of issue: *****
Shipper: (Full name and address details of Shipper)
Vessel: *****
Load Port: *****
Port of Discharge: *****
Total No of Bags: ***** bags
Description of Goods: *****
Notify: (Full name and address details of Receiver)

We ***** (company name), as an independent international inspection company, within the limits of our intervention, certify the following:

.....

..... Containers Fumigation:

After stuffing, the following containers were fumigated with ***** kg of Phosphine whose active ingredient is Aluminium Phosphide with a concentration of 2 g/m³.

Container Nos: ***** ***** *****
***** ***** *****

Place and Time of Intervention: At ***** (country) terminal, on ***** (date).

All above findings are final at the place and time of our

intervention. Authorised Signatory: *****

FUMIGATION

*The Federation wishes to express its gratitude for the advice and contribution received from the Nederlandse Grondnoten Vereniging (Dutch Peanut Council) for the following **Guidelines and Safety Measures to be taken Before and During Discharging Containers Loaded with Groundnuts.***

Groundnut and oilseed containers are fumigated at the origin ports in order to prevent damage and infestation by insects during sea transport. Regarding the fumigation of groundnut containers, in trade there are some issues that should be highlighted. There have been a number of incidents whereby the containers did not have appropriate labelling or the fumigant had not been aerated from the containers.

The Dutch Peanut Council (DPC) studied these incidents and formulated some guidelines addressed to the countries of origin and a working instruction for those who unload the containers. They are aware that these guidelines cannot be all-embracing and that it is a random indication, but the issue is important enough to formulate a basic principle. The guidelines are not meant to be a strict protocol; they are merely a recommendation to those who deal with this particular matter.

OPTIONS FOR FUMIGATION

The following options apply for fumigation -

- a. No Fumigation - This can be considered during periods in the colder months when, in general, temperatures are low enough to prevent infestation.
- b. Fumigation at the Terminal and Aeration Before Loading on Board - Fumigation takes between 3-7 days (depending on current temperatures). After that period, the container must be aerated and residues of fumigation removed. A copy of the Certificates of Fumigation must be displayed on the inside of the container door showing the date of fumigation and aeration/removal of residues of fumigation.
- c. Fumigation in Transit - Containers are loaded on board shortly after fumigation at the terminal so that the gas can evaporate during the sea voyage. However, this process is influenced by the current temperatures in transit (low temperatures = slow evaporation; high temperatures = faster evaporation). In this case, a warning sticker is required. At destination, every container must be checked carefully for the presence of gas before unloading. When gas is still active, it may take days before the container will be aerated completely (dependent on current temperatures). Fumigation residues must be removed carefully.

If containers have been fumigated at origin, there must be appropriate warning of the fumigant used and fumigation documentation must be available at the port of destination. This will ensure that the appropriate procedures can be conducted by port authorities before and during the discharge of containers. Due to the phase-out of methyl bromide, it is recommended that it should be excluded as a fumigant and only phostoxine products should be used for the fumigation of groundnut shipments.

INTRODUCTION

In order to prevent damage of the above-mentioned products by insects during sea transport, fumigation with insecticides is often used. The two most frequently used insecticides are Phosphine and Methyl Bromide (vapour).

Phosphine is not brought into the containers as such, but is in the form of a solid substance which consists of a metal phosphide, usually aluminium phosphide. This substance will react with water vapour present in the air, resulting in the very toxic phosphine. The solid substance (metal phosphide) is packed in an air-permeating packing, so that exchange of water vapour and phosphine is possible. The packings should be placed into the container and be clearly visible. It should not be among the goods themselves. Various trade names are used for the metal phosphides; the most well known of which is Phostoxine.

Methyl Bromide vapour is brought into containers by the evaporation of methyl bromide liquid.

The quantities and way of application of both substances are attuned to their properties. Methyl bromide will kill the insects directly after application; while phosphine has to be in contact with the insects for a longer period of time in order to be effective. In theory, a parcel which has been treated with methyl bromide should have to be ventilated/aerated 24 hours after application in order to remove residues of the vapour. However, with regard to containers, this is often not the case, so that even weeks after applying methyl bromide, residues of the vapour are found in a container, especially among the packings. As mentioned above, phosphine is not used as such, but is chemically formed from the metal phosphatide. This substance is brought into the container after loading and will then immediately start to produce the gas. If the water content of the produce in the container is low, a low concentration of water vapour could be present in the container, so that the chemical reaction proceeds slowly and the substance is still active (produces gas) on arrival of the container in Europe. Also, at low temperatures, the evolution of phosphine is slow.

On the outside of containers, the contents of which were treated with one of these substances, clearly visible warnings should be present indicating that the substance in question was applied to the contents. However, it appears that these warnings are not present in all cases. As a matter of fact, each container (the contents of which were treated with methyl bromide or phostoxine) should be ventilated/aerated before sea-transport).

TOXICITY

The maximum allowed concentration (MAC value or TLV) in the respiratory tract of people when executing normal work during 8 hours is for -

Methyl Bromide	1 milligram/m ³ = 0,3 ppm (ppm = parts per million)
Phosphine	0,4 milligram/m ³ = 0,3 ppm

These concentrations are very low; the toxicity degree of both substances in respect of human beings is very high.

GENERAL

In the case of methyl bromide, there is a chance that among the stowed bags, in so-called "pockets", vapour is present in concentrations which are clearly higher than the above-mentioned maximum allowed values. To a smaller extent, this is the case with phosphine. When discharging the bags, these high concentrations may be liberated and spread through the container. When metal phosphides are used it can happen that, either caused by a too low water vapour concentration in the atmosphere in the container or caused by too low ambient temperatures, there is still liberate active phosphine on the arrival of the container in Europe. The result is a higher gas concentration in the container than the maximum allowed value.

For these reasons, it is necessary that each container which mentions on the outside that one of the above substances was used as an insecticide, is thoroughly tested on the presence of these gases before commencing the discharge. Also during discharge, measurements have to be carried out. It is strongly recommended to also carry out adequate measurements before and during discharge in containers which do not have this warning on the outside. Measurements have to be carried out in the right way with the appropriate apparatus.

PROPERTIES OF THE GASES

Methyl bromide is heavier than air (3,3:1). Phosphine is also heavier than air, but to a smaller extent (1,2:1). Therefore, methyl bromide will be present in "pocket" form among the bags in a stow sooner than phosphine. Inhaling the vapour in concentrations over the TLV value must be avoided at all times. Phosphine may penetrate the human body via the respiratory tract. When the gas is present in the surrounding air, respiratory protection has to be used (compressed air masks). The human body, via the respiratory tract and the skin, absorbs methyl bromide. If the vapour is present in the surrounding air (or may be present), besides respiratory protection, protective clothing (gas-tight) must also be used.

RECOMMENDED METHODS OF MEASUREMENTS

1. Testing the atmosphere in containers on the possible presence and concentration of phosphine.
 - 1.1 Place the closed container in the open air, preferably with the side which has to be opened against the direction of the wind.
 - 1.2 Open the doors of the container and carry out a first measurement among and round the directly stowed bags, as far as possible.
 - 1.3a When the result of measurement is negative, give permission to start discharge of the bags, as far as measured.
 - 1.3b When the result of measurement is positive (gas proven to be present), ventilate/aerate the container for at least 30 minutes and then measure again according to 1.2. If necessary, repeat the manipulations until a negative measuring result has been obtained.
 - 1.4 After discharge of the first stow layers, carry out continuation-measurements according to 1.2 among the next bags in the container which can be reached. One and the other has to be repeated until the container is empty.

Note: Measurements have to be carried out by persons provided with respiratory protection (compressed air mask). Residual packings with insecticide (metal phosphide) have to be removed carefully (rubber/synthetic gloves) from the container and be considered as chemical waste. This means that the residues have to be stored in closed barrels in the open air in a place assigned for that purpose. When the residues are neutralised with water (and hypochlorite), it has to be taken into account that high concentration of phosphine will be liberated. Therefore, this action is risky and has to be carried out with respiratory protection.

2. Testing the atmosphere in containers on the possible presence and concentration of methyl bromide.
 - 2.1 Place the closed container in the open air, preferably with the side which has to be opened, against the direction of the wind.

- 2.2 Open the doors of the container and carry out a first measurement among and round the directly stowed bags, as far as possible.
- 2.3a When the result of measurement is negative, give permission to start discharge of the bags, as far as measured.
- 2.3b When the result of measurement is positive (gas proven to be present), ventilate/aerate the container for at least 30 minutes and then measure again according to 2.2. If necessary, repeat the manipulations until a negative measuring result has been obtained.
- 2.4 After discharge of the first stow layers, carry out continuation-measurements according to 2.2 among the next bags in the container which can be reached. One and the other has to be repeated until the container is empty.

Note - Measurements have to be carried out by skilled persons provided with respiratory protection (compressed air mask) and protective clothing). Residual packings of (and possibly with) methyl bromide have to be removed carefully and be considered as chemical waste.

Remark - When measuring, use an extension hose or anything like it (in the right way) in order to be able to measure well among the stowed bags.

APPARATUS FOR MEASURING CONCENTRATIONS OF VAPOURS/GASES

METHYL BROMIDE

1. Measurements with appropriate detection tubes are very selective and rather accurate. At ambient temperatures below freezing point, the measurement results are unreliable. Manufacturer : Dräger.

PHOSPHINE

1. Measurements with appropriate detection tubes are selective and rather accurate. At ambient temperatures below freezing point, the measurement results are unreliable. Manufacturers : Auer, Dräger.
2. Measurements with the "PAC III" - The apparatus is not selective and, when other gases/vapours are present, may indicate deviating (usually too high) concentrations. Manufacturer : Dräger.

MEASURES TO BE TAKEN BEFORE AND DURING DISCHARGE OF CONTAINERS

1. Put on compressed air mask and, in the case of methyl bromide, protective clothing.
2. Open container doors.
3. Visually check the inside of the container on the presence of residues from insecticides (small bags, tablets and powder point to metal phosphides; metal drums point to methyl bromide). Remove residues.
4. Carry out gas measurements with the appropriate measuring apparatus (Dräger, Auer) on residues of the gas belonging to the found remaining matter. If no residues were observed, carry out measurements on both substances. Pay attention that the right apparatus is used in the correct way. Take into account deviations in measurement results during frost.

5. When the measurement result is negative, start discharging the bags, as far as possible.
6. Carry out continuation-measurements among and round the bags freed after the first discharge.

Remark - As especially with methyl bromide, vapour is heavier than air, in spaces among packings in the stow, high concentrations of the vapour may be present. Therefore, it is recommended to constantly carry out measurements during the discharge procedure. When a measurement indicates that traces of phosphine, respectively methyl bromide, are present, leave the container immediately. After ventilating/aerating for at least 30 minutes, measurements have to be carried out again. Only after it has been established that no longer any vapour or gas is present, discharge can be started. During ventilating/aerating, the surroundings of the container have to be shielded.

Residues in solid form of the insecticides mentioned have to be considered as chemical waste. They have to be removed immediately from the container and stored in the open air in a secured place. Metal phosphides must not be brought into contact with water as, in that case, a high concentration of hydrogen phosphide gas may immediately develop. When you carry out neutralisation, this has to be done by persons provided with respiratory protection. When no neutralisation is carried out, residues have to be carried off safely and as fast as possibly to an appropriate waste processing installation. Neutralisation and storage of residues must always take place in the open air.



FOSFA International,
Augustine House, 6a, Austin Friars,
London, EC2N 2HA
United Kingdom

T: +44 (0)207 374 2346 | W: www.fosfa.org | [in](#)